



ISO/TC 184/SC 4/WG 15 "Digital manufacturing"
Convenorship: ANSI
Convenor: Hardwick Martin Dr



ISO CD 23247-5_Aug 08 2024 Digital Thread for Digital Twin

Document type	Related content	Document date	Expected action
Ballot / Reference document	Meeting: Stavanger (Norway) 18 Oct 2024 Project: ISO/AWI 23247-5	2024-08-08	VOTE by 2024-08-14

Replaces: N 273 ISO WD 23247-5_May 09 2024_clean

Description

This is a draft for review of the CD for ISO 23247-5 Digital Thread for Digital Twin. On August 14 there will be a meeting of WG15 to confirm that the document is ready to begin its CD ballot. When that ballot begins each member country will have an opportunity to make comments on the document. The comments will be used to improve the Draft International Standard which will be produced after the CD ballot and industry testing.

Automation systems and integration — Digital twin framework for manufacturing — Part 5: Digital thread for digital twin

CD stage

Warning for WDs and CDs

This document is not an ISO International Standard. It is distributed for review and comment. It is subject to change without notice and may not be referred to as an International Standard.

Recipients of this draft are invited to submit, with their comments, notification of any relevant patent rights of which they are aware and to provide supporting documentation.

© ISO 20XX

All rights reserved. Unless otherwise specified, or required in the context of its implementation, no part of this publication may be reproduced or utilized otherwise in any form or by any means, electronic or mechanical, including photocopying, or posting on the internet or an intranet, without prior written permission. Permission can be requested from either ISO at the address below or ISO's member body in the country of the requester.

ISO copyright office
CP 401 • Ch. de Blandonnet 8
CH-1214 Vernier, Geneva
Phone: +41 22 749 01 11
Email: copyright@iso.org
Website: www.iso.org

Published in Switzerland

Contents

Foreword.....
Introduction.....
1 Scope.....
2 Normative references.....
3 Terms and definitions.....
4 General.....
4.1 Concept of digital thread.....
4.2 Digital thread for digital twin.....
5 Operational procedure of digital twin using digital thread.....
5.1 General.....
5.2 Elements and interaction of digital twin using digital thread.....
5.3 Operational procedure of finding data from digital thread.....
5.4 Operational procedure of updating digital thread.....
5.5 Operational procedure between multiple digital thread entities.....
6 Requirements.....
6.1 General.....
6.2 Maintaining digital threads.....
6.3 Publication of digital threads.....
6.4 Querying for digital thread.....
6.5 Object, data store, and digital thread.....
6.6 Accessing object.....
6.7 Updating object and digital thread.....
6.8 Digital thread security.....
6.9 System architecture aspect.....
7 Reference architecture.....
7.1 General.....
7.2 Functional entities of digital twin related to digital thread.....
7.3 Functional entities of digital thread entity.....
Annex A (informative) Digital twin prototype, digital twin instance, and digital twin aggregate.....
A.1 General.....
A.2 Digital twin prototype (DTP).....
A.3 Digital twin instance (DTI).....
A.4 Digital twin aggregate (DTA).....
A.5 Relationship between digital thread and three types of digital twin.....
Annex B (informative) Detailed description of digital thread.....
B.1 General.....
B.2 Functional objective of digital thread.....
B.2.1 Digital thread creation.....
B.2.2 Digital thread management.....
B.2.3 Digital thread termination.....

Bibliography.....

Foreword

ISO (the International Organization for Standardization) is a worldwide federation of national standards bodies (ISO member bodies). The work of preparing International Standards is normally carried out through ISO technical committees. Each member body interested in a subject for which a technical committee has been established has the right to be represented on that committee. International organizations, governmental and non-governmental, in liaison with ISO, also take part in the work. ISO collaborates closely with the International Electrotechnical Commission (IEC) on all matters of electrotechnical standardization.

The procedures used to develop this document and those intended for its further maintenance are described in the ISO/IEC Directives, Part 1. In particular, the different approval criteria needed for the different types of ISO documents should be noted. This document was drafted in accordance with the editorial rules of the ISO/IEC Directives, Part 2 (see www.iso.org/directives).

ISO draws attention to the possibility that the implementation of this document may involve the use of (a) patent(s). ISO takes no position concerning the evidence, validity or applicability of any claimed patent rights in respect thereof. As of the date of publication of this document, ISO [had/had not] received notice of (a) patent(s) which may be required to implement this document. However, implementers are cautioned that this may not represent the latest information, which may be obtained from the patent database available at www.iso.org/patents. ISO shall not be held responsible for identifying any or all such patent rights.

Any trade name used in this document is information given for the convenience of users and does not constitute an endorsement.

For an explanation of the voluntary nature of standards, the meaning of ISO specific terms and expressions related to conformity assessment, as well as information about ISO's adherence to the World Trade Organization (WTO) principles in the Technical Barriers to Trade (TBT), see www.iso.org/iso/foreword.html.

This document was prepared by Technical Committee ISO/TC 184, *Industrial automation systems and integration*, Subcommittee SC 4, *Industrial data*.

A list of all parts in the ISO 23247 series can be found on the ISO website.

Any feedback or questions on this document should be directed to the user's national standards body. A complete listing of these bodies can be found at www.iso.org/members.html.

Introduction

The ISO 23247 series defines a framework to support the creation of digital twins of observable manufacturing elements including personnel, equipment, materials, manufacturing processes, facilities, environment, products, and supporting documents.

A digital twin assists with detecting anomalies in manufacturing processes to achieve functional objectives such as real-time control, predictive maintenance, in-process adaptation, Big Data analytics, and machine learning. A digital twin monitors its observable manufacturing element by constantly updating relevant operational and environmental data. The visibility into process and execution enabled by a digital twin enhances manufacturing operation and business cooperation.

The type of manufacturing supported by an implementation of the ISO 23247 framework depends on the standards and technologies available to model the observable manufacturing elements. Different manufacturing domains can use different data standards. As a framework, this document does not prescribe specific data formats and communication protocols.

The scopes of the four parts of this series are defined below:

- ISO 23247-1: General principles and requirements for developing digital twins in manufacturing;
- ISO 23247-2: Reference architecture with functional views;
- ISO 23247-3: List of basic information attributes for the observable manufacturing elements;
- ISO 23247-4: Technical requirements for information exchange between entities within the reference architecture;
- ISO 23247-5: Digital thread for digital twin;
- ISO 23247-6: Digital twin composition.

Figure 1 shows how the six parts of the series are related.

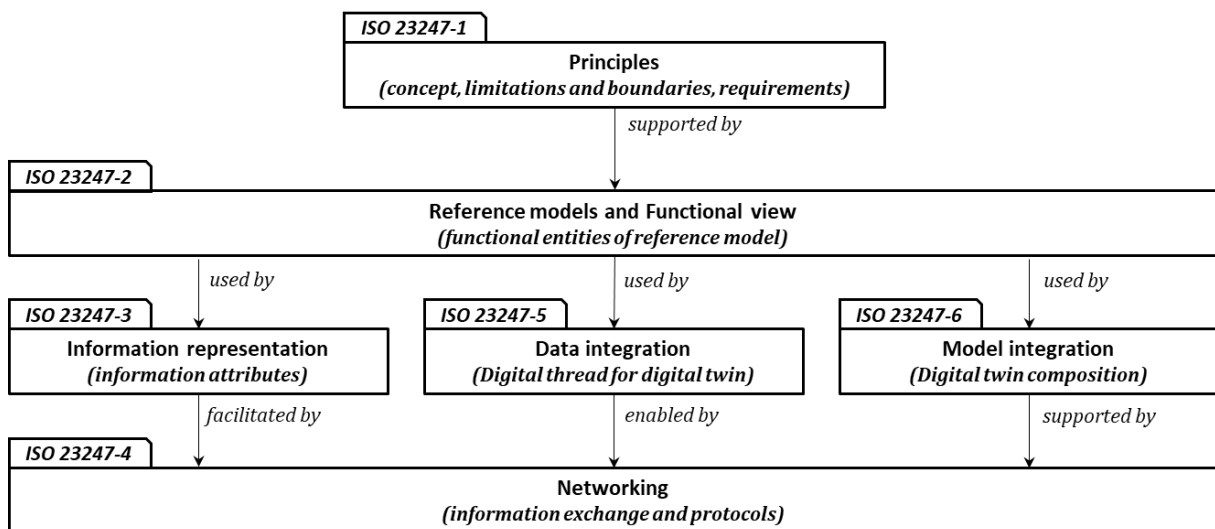

Figure 1 — ISO 23247 structure

This part describes how the digital thread supports the generation, implementation and transformation of digital twins in manufacturing.

In manufacturing where the digital twin does not have support from the digital thread, data from various stages of the manufacturing process – such as design, production, quality management, and maintenance - remains isolated within separate systems. This isolation causes data and information to be fragmented leading to delays and disruption for the digital twin in synchronizing and integrating information across

the manufacturing processes. This causes problems for the digital twin to conduct simulations and analyses, as these functions depend on a continuous and integrated data flow. The absence of a digital thread makes it difficult to associate various events and complicates time series analysis. The disconnection of information can cause delays in retrieving and processing data, subsequently leading to delays in decision-making and difficulty in addressing issues as they arise.

The digital thread facilitates the creation, connectivity, management and maintenance of manufacturing information. It allows the digital twin to express the various aspects and changes across manufacturing processes. The digital thread ensures that needed information is readily, reliably, and securely accessible when needed.

The scalability and adaptability of digital twins can be enhanced by digital thread, which supports seamless integration of new data sources and extension of digital twins to the entire product life cycle and multiple facilities.

This document outlines the framework of the digital thread for digital twins. This document defines the concept and operation procedure of using digital thread, requirements and reference architecture of digital thread to support digital twins for manufacturing.

Automation systems and integration — Digital twin framework for manufacturing — Part 5: Digital thread for digital twin

1 Scope

This part of ISO 23247 series specifies how the digital thread enables the creation, connectivity, management, and maintenance of manufacturing digital twins across the product life cycle by defining principles, showing methodologies, and providing use case examples.

2 Normative references

The following documents are referred to in the text in such a way that some or all of their content constitutes requirements of this document. For dated references, only the edition cited applies. For undated references, the latest edition of the referenced document (including any amendments) applies.

ISO 23247-1, *Automation systems and integration — Digital twin framework for manufacturing — Part 1: Overview and general principles*

ISO 23247-2, *Automation systems and integration — Digital twin framework for manufacturing — Part 2: Reference architecture*

ISO 23247-3, *Automation systems and integration — Digital Twin framework for manufacturing—Part 3: Digital representation of manufacturing elements*

ISO 23247-4, *Automation systems and integration — Digital twin framework for manufacturing — Part 4: Information exchange*

3 Terms and definitions

For the purposes of this document, the following terms and definitions apply.

ISO and IEC maintain terminology databases for use in standardization at the following addresses:

- ISO Online browsing platform: available at <https://www.iso.org/obp>
- IEC Electropedia: available at <https://www.electropedia.org/>

3.1

digital thread

<digital twin>

a fit for purpose information enabler for the connected digital twins for manufacturing

Note 1 to entry: the information enabler is identifying/accessing/exchanging/utilizing/sharing of information needed for digital twins.

3.2

digital twin prototype

DTP

informational sets necessary to describe and produce a physical version that duplicates or twins the virtual version, including, but not limited to, requirements, fully annotated 3D model, bill of materials (with material specifications), bill of processes, bill of services, and bill of disposal

3.3
digital twin instance
 DTI

digital twin of a single OME that is linked throughout its life cycle. It is derived from digital twin prototype

3.4
digital twin aggregate
 DTA

aggregation of multiple digital twin instance based on one digital twin prototype. Unlike the digital twin instance, the digital twin aggregate may not be an independent data structure.

3.5
observable manufacturing elements
 OME

item that has an observable physical presence or operation in manufacturing.

Note 1 to entry: Observable manufacturing elements include personnel, equipment, material, process, facility, environment, product, and supporting document.

[SOURCE: ISO 23247-1:2021(en), 3.2.5]

3.6
data store

organized and persistent collection of data and information that allows for its retrieval.

[SOURCE: ISO/IEC/IEEE 15939:2017(en), 3.6]

4 General

4.1 Concept of digital thread

A digital thread for manufacturing domain is a connected communication mechanism for contextualized manufacturing data, ensuring a seamless flow of information across all aspects of digital manufacturing. The primary aim of the digital thread is to provide a comprehensive and extendable representation of the information utilized within the manufacturing systems to enable efficient collaboration and decision-making throughout all stages of the manufacturing process.

The data in the digital thread is sourced from information system that support and enable the physical object represented by the digital twin and is contextualized for traceability. This allows users to monitor the status of the observable manufacturing elements (OME), thereby enhancing the visibility of the production process.

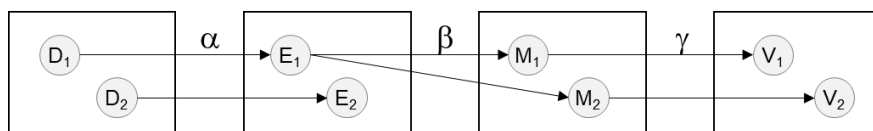

Key

- | | | | |
|---------------------------------|-----------------------------|---------------------------------|---|
| D ₁ , D ₂ | objects of design data | M ₁ , M ₂ | objects of manufacturing data |
| E ₁ , E ₂ | objects of engineering data | V ₁ , V ₂ | objects of validation data |
| → | link that connects objects | α, β, γ | links between D ₁ and E ₁ , E ₁ and M ₁ , M ₁ and V ₁ |

Figure 2 — Representative example of digital thread

Figure 2 shows a representative example of a digital thread. A digital thread consists of a series of objects and links. An object is a distinct unit of data with unique identifiers and other descriptive information that represents the OME. These objects serve as a building block of the digital thread, as they are connected through links. A link is a reference or pointer that connects one object to another to establish a relationship between the objects. Organizing these objects and links constitutes a digital thread that traces the data flow and transformation across various stages of the manufacturing life cycle.

Figure 2 illustrates a flow of data through different stages of the manufacturing life cycle. The description of each object is as follows:

- Objects (D_1, D_2) represent data of an initial design such as specifications, CAD, etc.
- Objects (E_1, E_2) represent detailed engineering data such as simulation, technical drawing, and analysis results. An object (E_1) is connected to object (D_1) with link (α) to indicate that engineering data is built from the design data.
- Objects (M_1, M_2) represent manufacturing data such as machine setting and production scheduling. An object (M_1) is connected to object (E_1) with link (β) to indicate the engineering plans are realized through manufacturing.
- Object (V_1, V_2) represents testing and validation data such as performance metrics, and test results. An object (V_1) is connected to object (M_1) with link (γ) to indicate the verification and validation of manufacturing outputs.

Thus, any changes to object (D_1) will be effecting changes to object (E_1), object (M_1), and object (V_1). With digital threads, it is possible to understand how data are changed and influenced to subsequent stages.

A detailed description of the digital thread is in Annex B.

4.2 Digital thread for digital twin

The digital twin provides a holistic view of OME, which needs a wide range of data for different stages of OME life cycle. The digital thread provides data from the design to the validation phase and is seamlessly integrated and available to the digital twin.

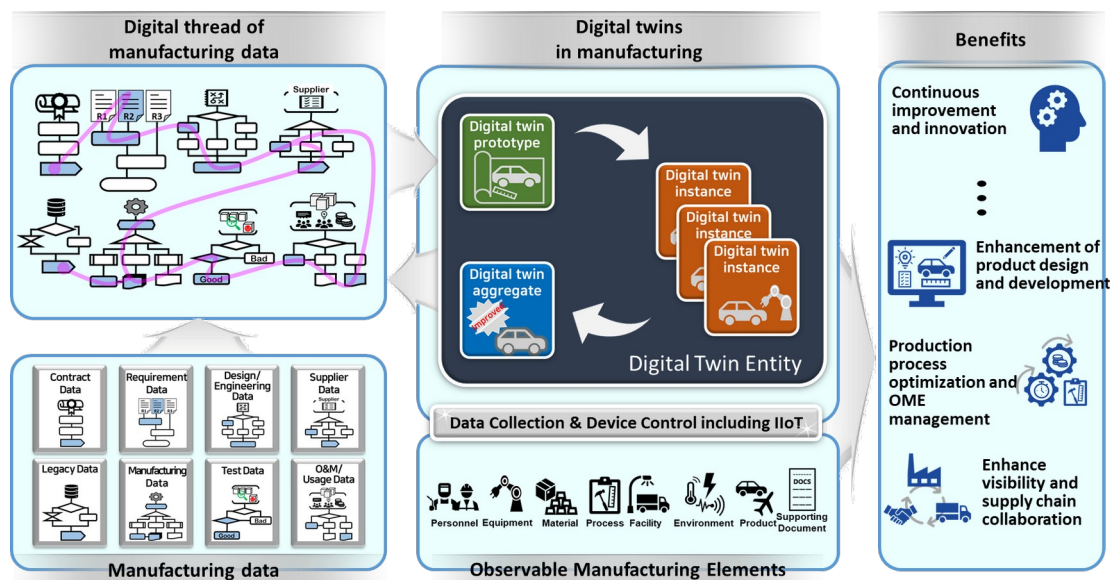

Figure 3 — Digital twin utilization of digital thread

Figure 3 shows how the digital twin utilizes the manufacturing data of digital threads. The digital twin uses the data from digital threads to obtain base information on the manufacturing data and model components for data analysis and optimization to represent the characteristics of the target OME. The digital thread enables the interpretation of data from different sources.

Using the manufacturing data from the digital threads, digital twin evolves in the form of digital twin prototypes, digital twin instances, and digital twin aggregates. A detailed description of the digital twin prototypes, digital

twin instances, and digital twin aggregates and in using digital thread are in Annex A. In this process, the digital twin changes based on the information gathered from the OMEs. Consequently, the digital twin generates new data which are provided as feedback into the digital thread forming connections with the information source within the digital thread. This feedback can be any kind of data within the life cycle, e.g., design, manufacturing, supplier, or test.

The digital twin initiates an information request that is interpreted by the digital thread. The interpretation of the digital twin information request facilitates an interrogation and retrieval of information/data resources that are deemed “trusted” and which the digital thread has authorized access. The digital thread proxies the access control authorization of the digital twin to acquire the requested data.

The use of digital thread by the digital twin can have many benefits. The major benefit is that it can provide continuous enhancement and innovation within manufacturing. This leads to the enhancement of efficiency in product design and development and improved decision-making. Furthermore, the digital thread allows for a comprehensive view of the product life cycle, which results in better traceability, quality control, and the ability to predict and address issues proactively. The digital thread can provide information for the digital twin to enhance visibility, which leads to enhancement in cooperation and supply chain collaboration in overall productivity in manufacturing.

5 Operational procedure of digital twin using digital thread

5.1 General

This clause describes how digital thread is operated and how digital thread is used by digital thread.

5.2 Elements and interaction of digital twin using digital thread

Figure 4 illustrates the elements and interaction of digital twins, digital threads, and associated data stores.

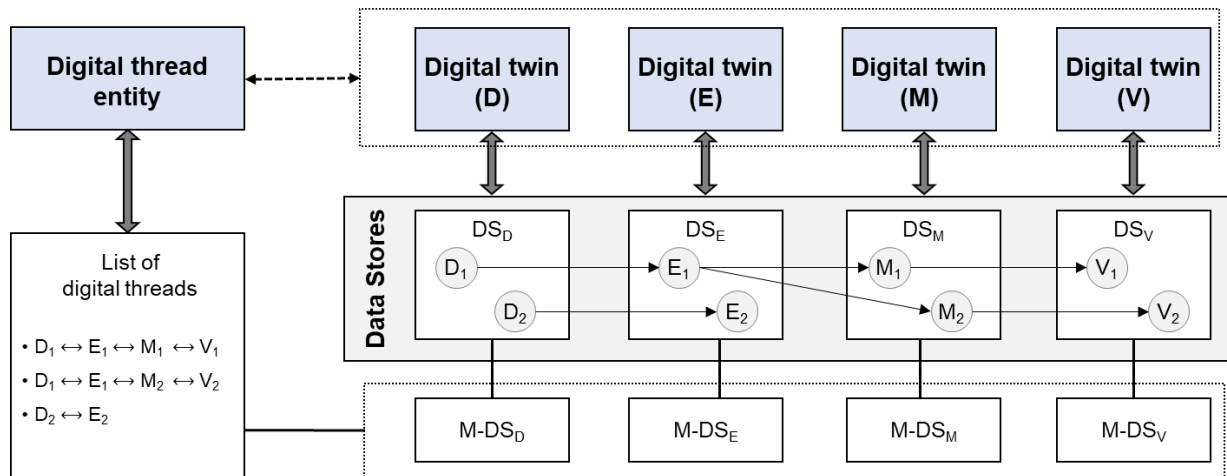

Key

Digital twin (D)	digital twin used in design stage	DS _D	data store for design data
Digital twin (E)	digital twin used in engineering stage	DS _E	data store for engineering data
Digital twin (M)	digital twin used in manufacturing stage	DS _M	data store for manufacturing data
Digital twin (V)	digital twin used in validation stage	DS _V	data store for validation data
M-DS _D	metadata for DS _D (contains D ₁ , D ₂)	D ₁ , D ₂	objects of design data
M-DS _E	metadata for DS _E (contains E ₁ , E ₂)	E ₁ , E ₂	objects of engineering data
M-DS _M	metadata for DS _M (contains M ₁ , M ₂)	M ₁ , M ₂	objects of manufacturing data
M-DS _V	metadata for DS _V (contains V ₁ , V ₂)	V ₁ , V ₂	objects of validation data
→	link indicating reference	↔	accessing data stores
↔	relationship for synchronization	↔	communication channel

$D_1 \leftrightarrow E_1 \leftrightarrow M_1 \leftrightarrow V_1$ digital thread \longleftrightarrow managing the list of digital threads

Figure 4 — Elements and interaction of digital twin using digital thread

There are many types of digital twins represented, each corresponding to different phase or aspects of the manufacturing life cycle. The digital twin accesses and utilises data from various data stores for a range of purposes such as simulation, optimization, etc.

The data store is a repository that holds a series of objects generated throughout the manufacturing process. There are multiple data stores, each designated for storing objects from different manufacturing stages. For example, an object generated during the design phase is stored in the data store for design, while object generated during the engineering phase is stored in the data store for engineering.

NOTE Objects and data generated from different manufacturing stages may or may not be stored in the same physical storage.

The object within the data store is linked to a referenced object from other data stores, establishing a digital thread that traces back to the source. This series of links forms a continuous digital thread originating from the object's initial source.

NOTE 1 D_1 and D_2 are objects in the data store for design (DS_D); E_1 and E_2 are objects in the data store for engineering (DS_E); M_1 and M_2 are objects in the data store for manufacturing (DS_M); and V_1 and V_2 are objects in the data store for validation (DS_V).

NOTE 2 V_1 is derived from M_1 , which itself is derived from E_1 , originally generated from D_1 . This sequence constructs a digital thread that links $D_1 \leftrightarrow E_1 \leftrightarrow M_1 \leftrightarrow V_1$, demonstrating a continuous and traceable flow of object data from design through validation.

EXAMPLE 1 D_1 in the data store for design can be a CAD model (AP242) and D_2 can be a simulation design.

EXAMPLE 2 E_1 in the data store for engineering can be an assembly instruction (AP210) and E_2 can be the simulation and analysis results.

EXAMPLE 3 M_1 in the data store for manufacturing can be CNC machine programming codes (AP238) and M_2 can be manufacturing status reports via MTconnect protocol.

EXAMPLE 4 V_1 in the data store for validation can be stress test and performance results and V_2 can be failure rate analysis.

Metadata (i.e., $M-DS_D$, $M-DS_E$, $M-DS_M$, $M-DS_V$) is maintained for each data store, providing abstract information about the contents of the data store. The metadata includes identifiers (IDs) of the object retained within the data store, which are used to access specific data entries. Additional details of the metadata include the date of creation, the process that generated the object, and any existing links that references objects from other data stores.

NOTE Metadata may or may not be stored in the same physical storage with the corresponding data store.

A digital thread entity is a component that stores and manages digital threads within manufacturing environments. The digital thread entity publishes the digital threads making it available to various digital twins. The publication can be conducted through the webpage, messaging systems such as MQTT, database access, cloud storage services, etc. The digital twin queries the digital thread entity to trace and locate data from the interconnected disparate data stores. Through analysis of the digital thread, the digital thread entity provides answers by proving the location and method of retrieving the needed data. The digital twin entity integrates and orchestrates the digital threads to support traceability across multiple data stores.

The list of digital threads contains digital threads that show how objects are transitioned from one phase to another within the manufacturing life cycle. The list of digital threads enables the retrieval of relevant and interconnected data from assorted data stores. Each node, identified by unique IDs, points to specific objects within the disparate data stores, enabling retrieval of interconnected data as requested by digital twins. The digital thread entity is responsible for managing and updating the list of digital threads to ensure its accuracy and

alignment with the data flows in the digital thread. This is achieved through the synchronization with the metadata of the data stores.

5.3 Operational procedure of finding data from digital thread

This clause describes the operational procedure of the digital twin finding data from the digital thread as illustrated in Figure 5.

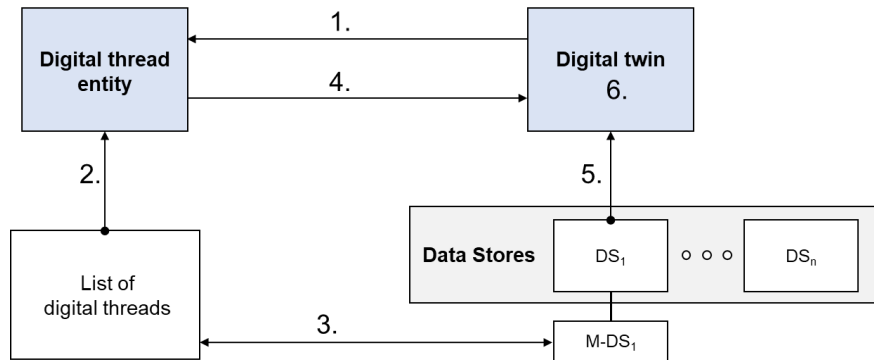

Key

- | | | | |
|----|---|--------------|---------------------------------|
| 1. | query initiation | DS_1, DS_D | n numbers of data stores |
| 2. | searching the list of digital threads to answer the query | $M-DS_1$ | metadata associated with DS_1 |
| 3. | verify the validity of digital thread | | |
| 4. | query response with ID(s) of object(s) | | |
| 5. | retrieve object using ID(s) | | |
| 6. | utilize object | | |

Figure 5 — Operational procedure of finding data from digital thread by digital twin

The procedure is as follows:

1. Query initiation: digital twin initiates a query to the digital thread entity to help find specific data or a particular digital thread;

NOTE 1 The digital threads are published at the initiation of the digital thread entity. The methods of querying digital threads depend on the technology implemented for publication.

2. Search: digital thread entity searches the list of digital threads to find the requested object or digital thread;
3. Verify: digital thread entity checks the metadata of the data store to verify digital thread and to retrieve information related to accessing the object(s).
4. Query response: upon finding the requested object(s), the digital thread entity provides the digital twin with the object ID(s) and other information to access corresponding data store;

NOTE 2 The digital thread entity must ensure that the digital twin has the appropriate permissions to access the requested object. Therefore, responses may vary based on the access rights of the requester.

5. Retrieve object: using the ID or multiple IDs provided, the digital twin retrieves necessary objects or data from the data store;
6. Utilise object: the digital twin uses the newly retrieved data for its intended purposes.

5.4 Operational procedure of updating digital thread

This clause describes the operational procedure of the digital twin in updating data as illustrated in Figure 6.

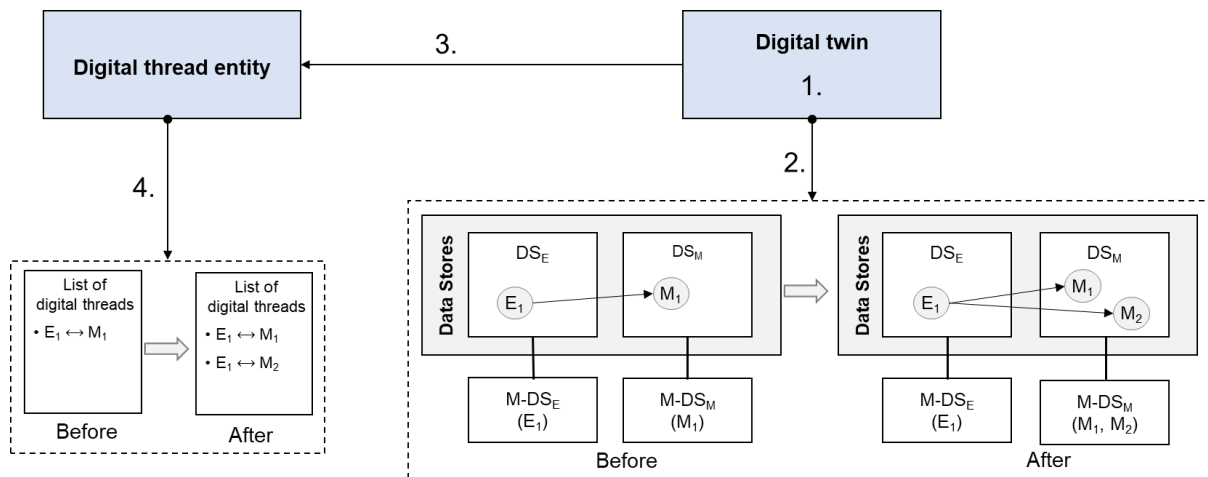

Key

- | | | | |
|----|--|------------|---|
| 1. | creation of new object (M_2) using E_1 | DS_E | data store for engineering data |
| 2. | update data store: add M_2 and new link ($E_1 \rightarrow M_2$) | DS_M | data store for manufacturing data |
| 3. | notification of new link ($E_1 \rightarrow M_2$) | E_1 | object of engineering data |
| 4. | update list of digital threads: add digital thread ($E_1 \leftrightarrow M_2$) | M_1, M_2 | objects of manufacturing data |
| → | link indicating reference | $M-DS_E$ | metadata on DS_E (contains E_1) |
| ⇒ | change of state from before to after | $M-DS_M$ | metadata on DS_M (contains M_1, M_2) |

Figure 6 — Operational procedure of updating digital thread

The procedure is as follows:

1. Creation of new manufacturing data: the digital twin uses existing engineering object (E_1) to create new manufacturing object (M_2).
This process demonstrates how the digital twin generate new object based on the predefined inputs and conditions.
2. Update data store: the digital twin stores the M_2 to the data store for manufacturing and add new link from E_1 to M_2 .
The link between M_2 and E_1 , indicates the linkage and dependency of the two objects.
Figure 6 shows the state of the data store before and after the updates, showing how M_2 is linked to E_1 ;
3. Notification of changes: the digital twin notifies the digital thread entity on creation new digital thread ($E_1 \rightarrow M_2$);
4. Update list of digital threads: the digital thread entity updates its list of digital threads to include new digital thread ($E_1 \rightarrow M_2$).
Figure 6 shows the state of the list of digital threads before and after the update, showing how the new thread ($E_1 \rightarrow M_2$) is added.

5.5 Operational procedure between multiple digital thread entities

This clause describes the operational procedure between multiple digital thread entities as illustrated in Figure 7. It is impractical for a single digital thread entity to manage every data store due to the vast number of objects and data involved. It is possible to have multiple digital thread entities, each responsible for managing specific data stores. The digital thread entities publish details about the objects they manage, allowing the digital twins to access and utilise the data stores under their control. This distributed management approach is logical in case where multiple manufacturers and suppliers are involved, as it enables cooperation and data sharing.

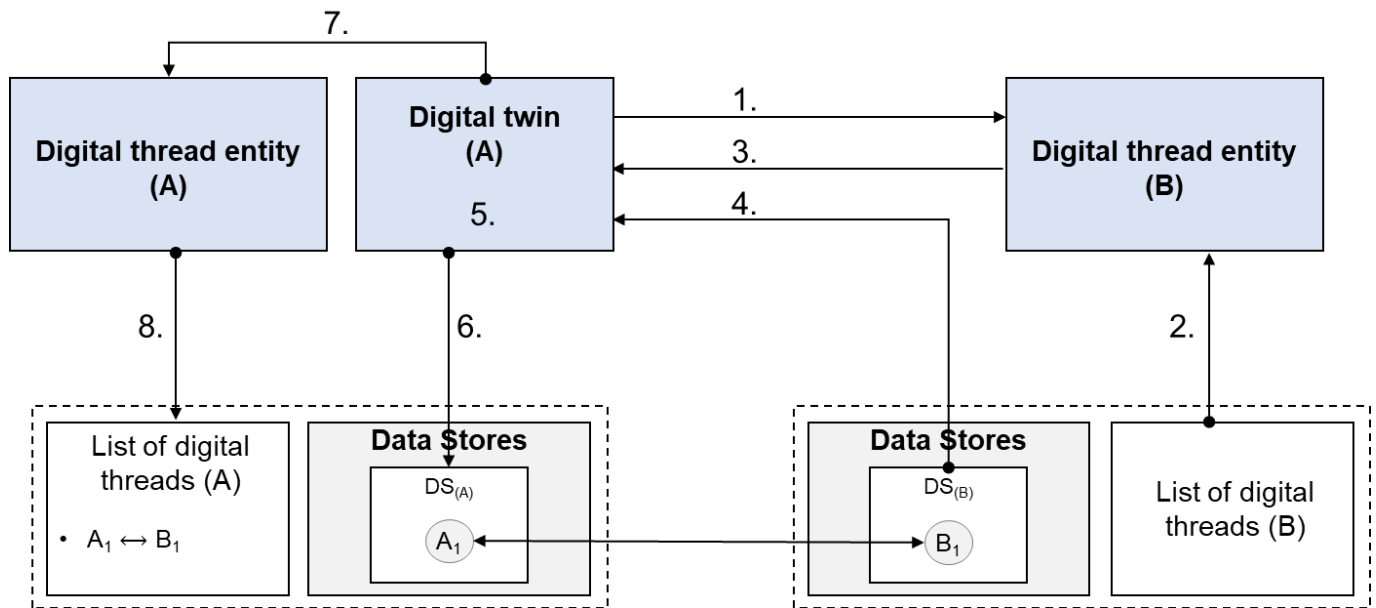

Key

- | | | |
|---|-------------------------------|---------------------------|
| 1. query initiation | A_1 | object of A domain |
| 2. search | B_1 | object of B domain |
| 3. query response with B_1 | $DS_{(A)}$ | data store of A domain |
| 4. retrieve object B_1 | $DS_{(B)}$ | data store of B domain |
| 5. map A_1 to B_1 | \longleftrightarrow | link indicating reference |
| 6. update data store: add new link ($A_1 \rightarrow B_1$) | $A_1 \longleftrightarrow B_1$ | digital thread |
| 7. notification of changes ($A_1 \rightarrow B_1$) | | |
| 8. update list of digital threads: add digital thread ($A_1 \rightarrow B_1$) | | |

Figure 7 — Operational procedure between multiple digital thread entities

In Figure 7, the digital twin (A) is retrieving object from digital thread entity (B), and new thread is added from data store for (A) to data store for (B). The procedure is as follows:

1. Query initiation: the digital twin (A) initiates a query to digital thread entity (B) to find specific object or digital threads that it manages;
2. Search: the digital thread entity (B) searches the list of digital threads (B) to find the requested object or digital thread;
3. Query response: upon finding the requested object or thread, the digital thread entity (B) provides the digital twin (A) with the appropriate ID(s) of objects and information needed to access the data store $DS_{(B)}$. Note, in Figure 7, it is B_1 ;
4. Retrieve object: using the ID or multiple IDs provided, the digital twin (A) retrieves B_1 from the data store $DS_{(B)}$;
5. Data utilization: the digital twin (A) uses data in object B_1 and maps object B_1 to its object A_1 to add dependency between the two objects;
6. Update data store: the digital twin (A) creates a direct link between A_1 and B_1 to indicate linkage and dependency.

The digital twin (A) can easily reference B_1 when needing detailed information about A_1 ;

7. Notification of changes: the digital twin (A) notifies the digital thread entity (A) of the new digital thread ($A_1 \rightarrow B_1$);
8. Update list of digital threads (A): the digital thread entity updates list of digital threads (A) to include a new digital thread ($A_1 \rightarrow B_1$).

6 Requirements

6.1 General

This clause defines the requirements of the digital thread entity and digital twin.

6.2 Maintaining digital threads

The digital thread entity shall store and manage the digital threads. Digital threads should be kept in a repository, denoted as the “list of digital threads.” The content in the list of digital threads include thread ID, timestamp, starting point and endpoint of the digital thread, list of IDs of data in multiple data stores.

The digital thread entity shall update the list of digital threads to synchronize with the changes of the digital threads within the multiple data stores.

6.3 Publication of digital threads

The digital thread entity shall publish information about the digital threads it manages. The digital twin uses that information to query and find objects or digital threads it needs.

EXAMPLE Publication is made through the webpage, messaging protocol such as MQTT, database access service, and cloud storage services.

6.4 Querying for digital thread

The digital thread entity shall provide a method to query for the digital twin to request the necessary objects or digital thread.

EXAMPLE Methods used for the query are API, web portal, database query interface, and messaging protocols.

The digital thread entity shall process the query and search the digital threads it manages to find the requested digital threads or objects.

The digital thread entity shall check the metadata of the data store to find necessary information for accessing objects within the data store. During this process, the digital thread entity may verify the validity of the digital thread to ensure synchronization between the list of digital threads and digital threads within the data stores.

The digital thread entity shall verify the identity of the digital twin to ensure it has the authority to access the object in the data store.

NOTE The metadata of the data store has information about the permission of access for each object.

The digital thread entity shall provide an identifier(s) and other information to access the object in the data store to facilitate the request of the digital twin.

EXAMPLE Identifying mechanisms such as UUID(Universally Unique Identifier), GUID(Globally Unique Identifier), IRDI(International Registration Data Identifier) can be used.

6.5 Object, data store, and digital thread

The data store shall contain a series of objects.

NOTE An object refers to a unit of data that include unique identifiers and other descriptive information. The object is a building block of the digital thread, as they are connected to represent the flow and transformation of information across multiple data stores.

An object shall have links to another object in different data store, if it is derived from that object.

A data store shall have corresponding metadata that has information about the data store. The metadata includes a list of identifiers, the creation and modification date and time, and the access rights for each object. The metadata shall include links if the corresponding object has links to another object.

EXAMPLE Metadata of a data store can use the semantic dictionary or ontology to express the content of the data store.

The objects from different data stores shall be interconnected to create a digital thread.

The digital thread existing among the data stores, the digital thread in the metadata of the data stores, and the digital thread in the list of digital threads shall be aligned.

The digital thread entity shall verify the consistency of the digital thread between the metadata of the data store and the list of digital threads.

NOTE The digital thread entity can verify the digital thread during processing of the digital twin's query.

The digital thread entity shall be interoperable with different types of data stores and metadata it manages to enable data exchange and integration across different environments.

6.6 Accessing object

The digital thread entity shall provide a method for the digital twins to access objects and digital threads in the data stores.

The digital twin should have appropriate authorization to access the data stores and the corresponding metadata of the data store.

The digital twin shall use the digital thread to seek additional information on other objects.

6.7 Updating object and digital thread

Upon creation of a new object, the digital twin shall create a link to the referenced object to ensure traceability. The new object should include a timestamp to indicate the time of its creation.

The digital twin shall create/delete/update the link of objects in the data store and the metadata of the data store.

The digital twin shall notify the digital thread entity if there is a change to the link between the objects.

Upon creation of new link, the digital thread entity shall decide whether to create a new thread or add the link to an existing digital thread in the list of digital threads.

The digital thread entity shall create/delete/update the digital thread in the list of digital threads.

NOTE Digital thread can be persistent or non-persistent.

Before removing the link of the digital thread, the digital twin should consider the following factors: reusability, regulatory/contractual retention requirement, inter and intra-enterprise utilisation, and functional integration with one or more processes.

Upon deletion of the link, the digital thread entity shall decide whether to split the digital thread into two separate digital threads or remove the object from the digital thread.

The digital thread entity shall ensure timely data interactions and maintain accurate association in the links of the digital thread.

6.8 Digital thread security

The digital thread entity shall implement security measures to ensure that information about the digital thread is not provided to unauthorised digital twins.

NOTE The metadata of the data store can include information about access rights. The digital thread entity may refer to this metadata of the data store to verify if the requesting digital twin has the appropriate access rights.

The digital twin should have appropriate authorisation to access the data stores and the corresponding metadata of the data store.

NOTE Refer to IEC 62443.

6.9 System architecture aspect

The digital twin entity shall be able to use digital thread.

7 Reference architecture

7.1 General

This clause defines the reference architecture of the digital thread entity and its relationship with the digital twin.

Figure 8 shows the digital thread reference architecture of the digital thread entity and the interface with the digital twin.

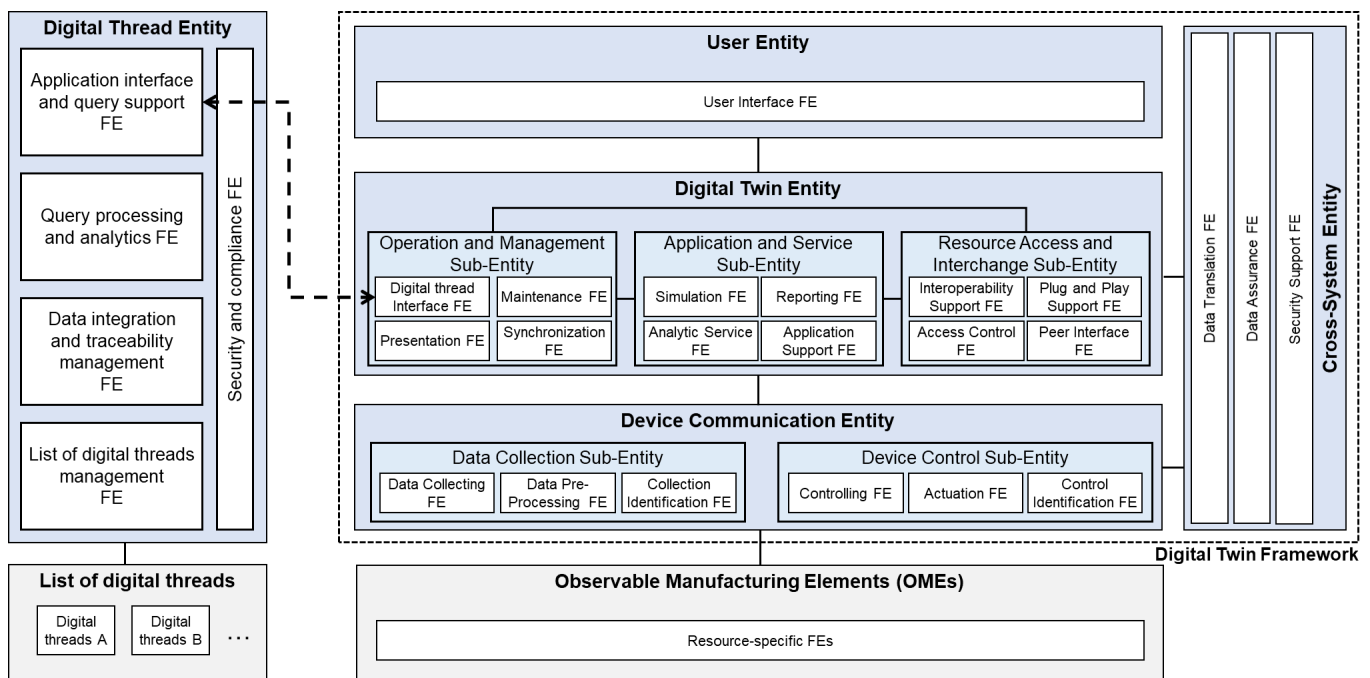

Figure 8 — Reference architecture of digital thread entity and interface with digital twin

7.2 Functional entities of digital twin related to digital thread

7.2.1 General

The reference architecture of the digital twin is defined in ISO 23247-2. The FEs in the digital twin entity access the data store to use and update objects and data. The FEs use the digital thread in various ways to accomplish their purposes. Digital threads have numerous roles in supporting the FEs, the following are some examples.

- Maintenance FE: integrates historical and real-time data to identify patterns and predict failures;
- Synchronization FE: integrates historical and real-time data to identify patterns and predict failures;
- Simulation FE: links design data with operational and performance data to enhance simulation accuracy;
- Reporting FE: collects and consolidates data from various data stores to generate in-depth reports;
- Analytic service FE: enable comparison between design plan, production results, and quality metrics to identify and address quality issues;
- Interoperability support FE: Ensures that data from different systems is integrated and interoperable, providing a unified view for the digital twin;
- Plug and play FE: enables data exchange between suppliers, manufacturers, and distributors;

7.2.2 Digital thread interface FE

The digital thread interface FE interacts with the digital thread entity to query and receive responses, and to notify changes in the links within the digital thread.

7.3 Functional entities of digital thread entity

7.3.1 Application interface and query support FE

The application interface and query support FE interacts with the digital twin to respond to queries. It also publishes and exchanges information about digital threads.

7.3.2 Query processing and analytics FE

The query processing and analytics FE handles queries to provide appropriate responses, adapted to be suitable for digital twins.

7.3.3 Data integration and management FE

The data integration and management FE creates digital threads by integrating, aggregating, and orchestrating objects. It makes sure that the objects in the digital thread are traceable. It ensures alignment between digital threads within the list of digital threads and the links across multiple data stores.

7.3.4 List of digital threads management FE

The list of digital threads management FE accesses and updates the list of digital threads.

7.3.5 Security and assurance FE

The security and assurance FE ensures the security of the digital thread which includes authentication, authorization, and confidentiality measures. It also ensures that the responses are appropriate to the access rights, capabilities, and environment of the querying digital twin.

Annex A

(informative)

Digital twin prototype, digital twin instance, and digital twin aggregate

A.1 General

According to reference, digital twins are categorized into three subtypes: digital twin prototype(DTP), digital twin instance(DTI), and digital twin aggregate(DTA). All three types of digital twins utilise the digital thread. This annex describes the relationship among the three digital twin subtypes and details how each types uses the digital thread.

A.2 Digital twin prototype (DTP)

The digital twin prototype(DTP) is an informational set necessary to describe and produce a physical version that duplicates or twins the virtual version, including, but not limited to, requirements, fully annotated 3D model, bill of materials (with material specifications), bill of processes, bill of services, and bill of disposal. The DTP includes necessary parameters and characteristics that describe the intended OME, however, it is not linked to a specific OME. It serves as a blueprint or initial model that can be used to create a digital twin instance.

The DTP represents the intended functionality, behaviour, and characteristics of the OME in the design stage. It enables stakeholders to observe and analyse how the DTP responds to different conditions, inputs, and use cases. It is used in testing and validating the design concept or digital model. It helps to identify potential problems or improvement of the design model at the early stage of manufacturing or development.

The DTP uses digital thread to acquire requirement data. By exploiting the requirement data with the digital model, DTP can mirror the specific operational needs and parameters used for simulation, analysis, and validation of the requirements.

A.3 Digital twin instance (DTI)

The digital twin instance(DTI) is a digital twin of a single OME that is linked throughout its life cycle. It is derived from the DTP. The DTI represents the design features, manufacturing details, operational behaviour, and performance of its corresponding OME. The DTI collects and integrates operational data from sensors or other sources to show an accurate and up-to-date view of the OME. The DTI monitors its OME by actively tracking the updates of its counterparts. The DTI is aligned with the entire life cycle of the OME it represents, which also means it is no longer needed when its counterpart is decommissioned. However, it is possible to maintain some information on DTI which is needed as a reference for the future development of the new OME.

With DTI presenting the current status of the OME, it can include detailed simulations that is used to predict future behaviour, analyse potential problems, or optimization to be used in supporting decision-making processes related to the management, maintenance, and disposition of the connected OME.

The DTI uses a digital thread to acquire data to align with the corresponding OME. The DTI uses the design data to ensure that DTI accurately reflects the OME specification and intended functionalities of the OME. The DTI is continuously updated by tracing digital threads of the manufactured data to reflect any changes to OME. This will ensure that the DTI is an up-to-date representation of the OME. The DTI provides prompt operational data and performance metrics back to the digital thread. The DTI is validated with the use of a digital thread of the validation data, which ensures that the DTI follows the quality requirement and operational criteria of the intended OME.

A.4 Digital twin aggregate (DTA)

The digital twin aggregate(DTA) is an aggregation of all the DTIs. Unlike the DTI, the DTA may not be an independent data structure. It may be a computing construct that has access to all DTIs and queries them either ad-hoc or proactively. The DTA provides a comprehensive view of the collective behaviour and performance of multiple DTIs.

NOTE Digital twin aggregate is different from digital twin aggregation. Digital twin aggregation is a process of integrating multiple DTIs of different DTPs. It is also known as digital twin composition.

The DTA represents collective the behaviour and operation of the DTIs. The gathered data are combined to identify patterns, correlations, and performance of the DTIs. The DTIs can be from different vendors or systems, and DTA can get an aggregated view of the multiple DTIs enabling analysis of the performance and interaction as a group. The DTA provides a detailed understanding of DTIs which can be used to support decision-making.

The DTA uses digital thread to acquire aggregated data from multiple DTIs. The digital thread acts as a single source of truth, ensuring consistency and reliability of data collected from DTIs. Without digital thread, data gathered from multiple DTIs can be inconsistent. It is meaningless to aggregate those data, and it could lead to errors in the decision-making process. The consistent and reliable data flow of digital thread enhances analysis, optimization, and decision-making. Also, the digital thread provides data across OME's life cycle which ensures that DTA has access to all necessary data for effective decision-support.

A.5 Relationship between digital thread and three types of digital twin

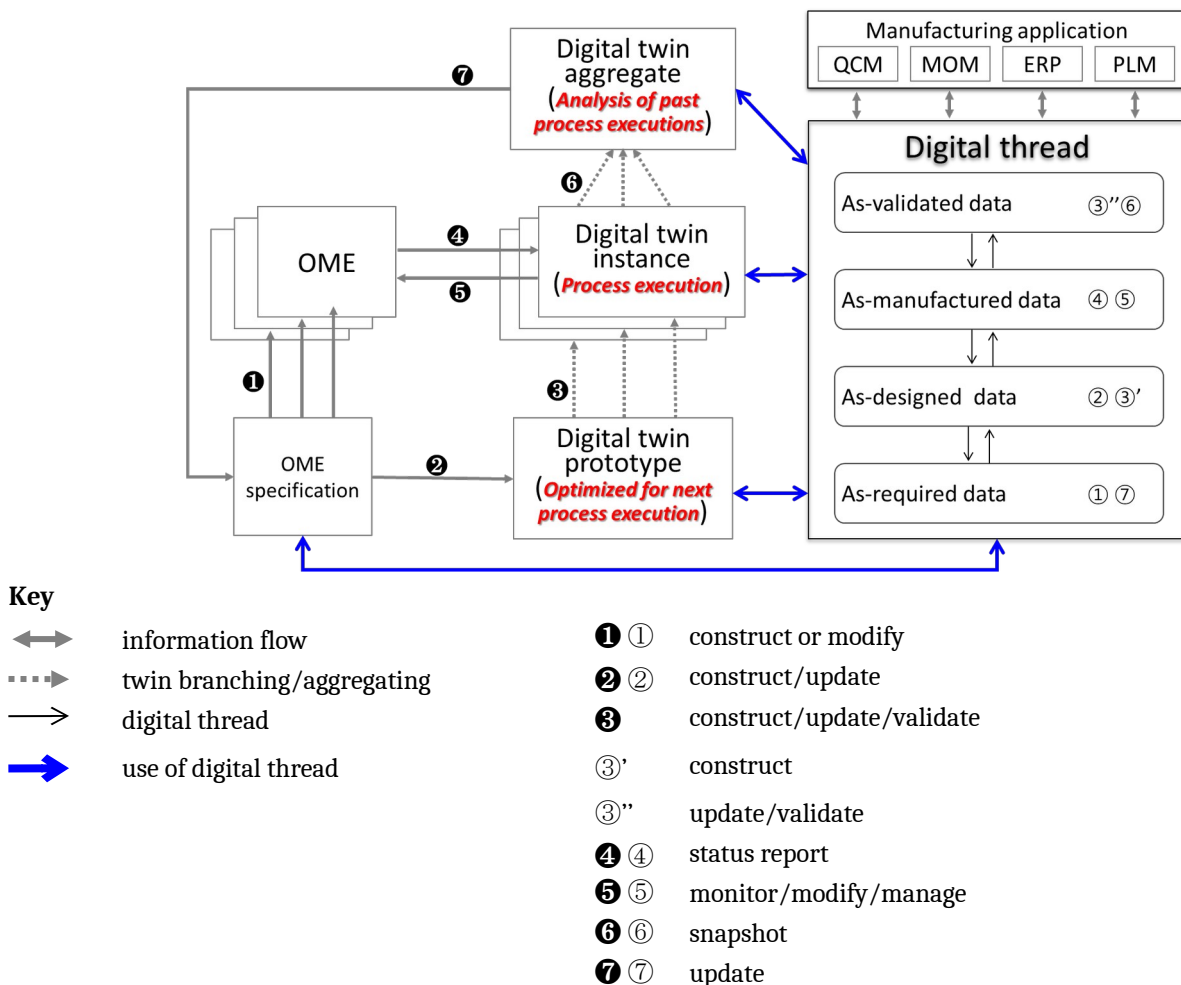

Figure A.1 — Relationship of digital thread and different types of digital twins

This document focuses on the requirement stage to the validation stage. Other stages are out of the scope of this document.

Figure A.1 shows the information flow and relationship among different types of digital twins, digital thread, OME, and OME specification. The description of each component is as follows:

— digital twin prototype(DTP)

It is a representation of a digital model that is optimized for the next process execution.

It is constructed or updated from the OME specification and production engineering, which is in the form of as-required data of digital thread.

It is used to construct, modify, and validate DTI by providing as-designed data and as-validated data to a digital thread;

— digital twin instance(DTI)

It is a representation of a single OME that is in process execution.

It is constructed or updated from the OME specification and production engineering, which is in the form of as-required data of digital thread.

To be synchronized with OME, it monitors and manages the OME to get the status report of the changes in OME which is in the form of as-manufactured data of digital thread.

It is a source of snapshots for DTA by providing as-validated data to the digital thread;

— digital twin aggregate(DTA)

It is a representation of aggregated DTIs to be used for the analysis of past process executions and used to make decisions for future improvement of OME specification.

It is an aggregate of snapshots of multiple DTIs, which is in the form of as-validated data of digital thread.

It is used to update OME specification as-validated data to a digital thread;

— observed manufacturing element(OME)

It is a physical or logical counterpart of digital twin instance.

It is constructed or modified from OME specification, which is in the form of as-required data of digital thread.

It is monitored and managed by DTI and provides status reports to DTI, in the form of as-manufactured data of digital thread;

— OME specification

It is an engineering specification of OME that is twined.

It is constructed or updated from the manufacturing application and is updated by DTA, which is in the form of as-required data of digital thread.

It is used to construct or modify OME, which is in the form of as-required data of digital thread.

— digital thread

It provides data and ensures the data flow of all manufacturing components(?) throughout the manufacturing life cycle. As of the scope of this document, provides four types of data.

As-required data: it is an initial requirement or specifications used for designing digital twin or production engineering.

As-designed data: it is a detailed design and manufacturing planning. It is used to construct digital twin prototype and digital twin instances.

As-manufactured data: it is a detailed collection of information from the manufacturing process.

As-validated data: it is a validation result if the manufactured product meets the requirements.

— manufacturing application

It is a group of applications that manages and optimizes the manufacturing process throughout the manufacturing life cycle. It provides data that are interconnected in the form of a digital thread.

Annex B (informative)

Detailed description of digital thread

B.1 General

A digital thread is the connected communication mechanism for contextualized life cycle data with support of the following aspects.

- The connected communication is enabled by standards and technologies;
- The communicated data spans the life cycle of OMEs;
- The data is contextualized for clear and extendable interpretation;
- The contextualized communication enables data traceability.

A digital thread connects data from all stages of the manufacturing life cycle. Such data includes design and engineering data, manufacturing data, testing data, and operational data. This connected communication mechanism ensures the seamless flow of data and provides integrated access to up-to-date and consistent manufacturing information across traditionally isolated processes. By linking data across various stages, manufacturers can get the right data at the right place at the right time which significantly improves decision-making and operational efficiency.

The data in the digital thread can be anything that is needed for manufacturing, the making of digital thread is use case dependent. The data itself may be propriety data, however, digital thread makes it possible to access and share data through information exchange.

B.2 Functional objective of digital thread

The complexity that characterizes the digital thread increases when many diverse systems must work together to achieve common objectives. In this context, a system of systems approach is needed to understand, design, produce, and sustain the digital thread system. This requires the integration and incorporation of many individually complex models of these systems within the digital thread. To achieve this objective a standardized methodology of digital thread creation, modification, and termination is required. Key characteristics of the digital thread entity includes: consistency management, bi-directional traceability, collaboration, analytics, reuse, and support for model-based definition.

B.2.1 Digital thread creation

The creation of a digital thread in support of utilizing the digital thread entity requires the use of defined digital thread definition standards. These include but are not limited to standardized structure of the digital thread, access and utilization control of the digital thread, adoption of access and usage control rights from the data sourcing system.

B.2.2 Digital thread management

The core objective of a digital thread framework is to monitor and measure the effectiveness of digital thread utilization. The digital thread framework essentially facilitates the construct of digital thread-segment definitions and relationships by using visual “n” dimensional objects in data stores to establish the use and behaviour of a unique digital thread composition. Graph models can be used to define the characteristics and nature of these digital thread links. Digital thread links are assessed based on qualitative attributes such as data standards, retention of data integrity, accuracy of the data, timeliness of data interface and interaction, and digital thread links association.

Based on these attributes, digital thread index is an aggregate of various factors such as standardization, efficiency, data quality, elasticity and complexity of digital thread object and its links. Standardization factor

represents % adherence of data standard for each object and links whereas efficiency factor determines the data object and link transfer either from one life cycle phase to other, or object to object interaction. Elasticity factor signifies the architectural scalability of digital thread whereas the complexity factor embodies the number of digital thread objects.

There are many different ways and means of representing a digital thread framework. One of the approaches to representing the digital thread framework is by using a dimensional graph model. A typical 2D digital thread framework is represented as a composition of digital thread objects and segments as shown in Figure A.2. Geometrically, digital thread object is represented as a circle and link is the line that connects the circles.

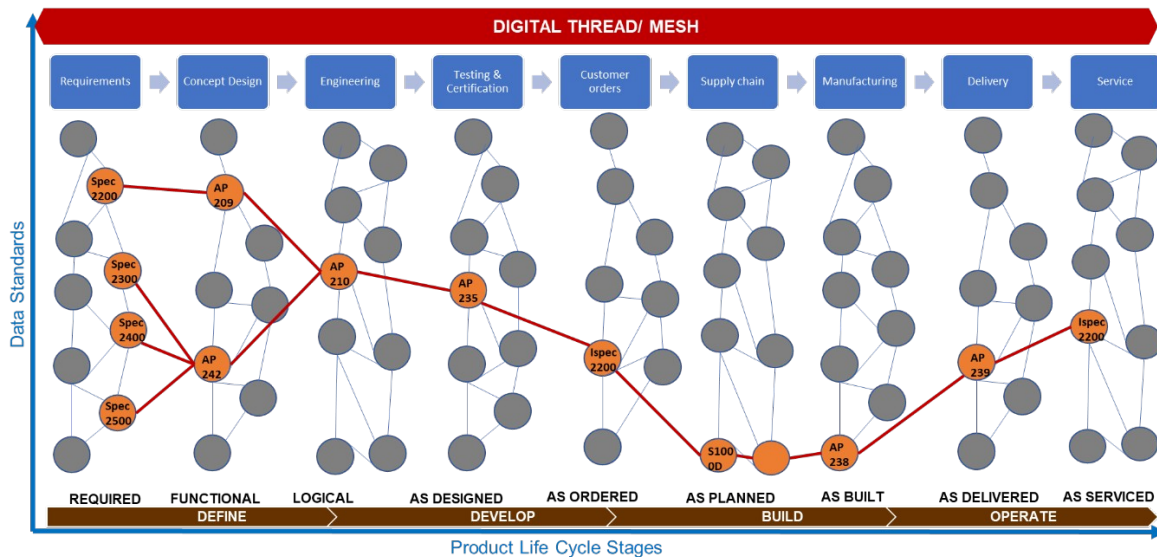

Figure A.2 — 2D Digital thread representation with data standards

The digital threads process layer is supported by data stores. In Figure A.3 with the 3D representation of a digital thread with 2 tier layers. Here data store can be either a structured data like a data base or cloud server, or it can be highly unstructured data like files present in the file server. Digital thread process layer is always connected with one or more data stores in the utilizing data store interfaces or application interfaces.

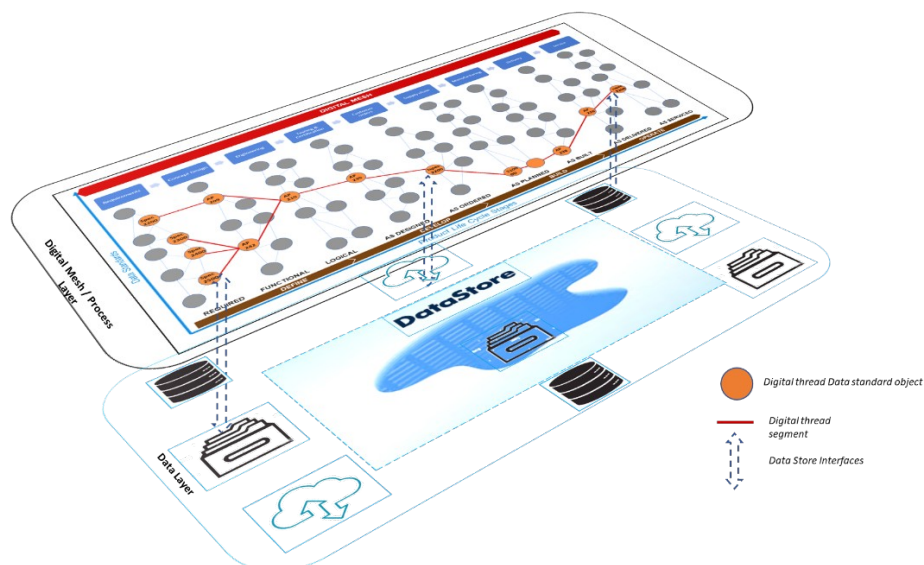

Figure A.3 — 3D Digital thread representation with 2 tier layers

B.2.3 Digital thread termination

The opportunity to terminate a digital thread requires a function of the intended use and anticipated duration of the digital thread. Ideally digital threads will become a critical element of information and knowledge retention. The following is a list of considerations that may contribute to the persistency of a digital thread: reusability, regulatory/contractual retention requirement, inter and intra enterprise utilization, and functional integration with one or more process or systems. Additional consideration must be taken to the intended use and anticipated persistency of the intended digital thread. Only those digital threads that are intended for personal research and not be intended for other uses, then these single use digital threads are candidate for termination.

Bibliography

- [1] IEC 62264 (series), *Enterprise-control system integration*.
- [2] ISO 10303-238, *Industrial automation systems and integration — Product data representation and exchange — Part 238: Application protocol: Model based integrated manufacturing*.
- [3] ISO 10303-242, *Industrial automation systems and integration — Product data representation and exchange — Part 242: Application protocol: Managed model-based 3D engineering*.
- [4] ISO 23247-1, *Automation systems and integration — Digital twin framework for manufacturing — Part 1: Overview and general principles*, 2021.
- [5] ISO 23247-2, *Automation systems and integration — Digital twin framework for manufacturing — Part 2: Reference architecture*, 2021.
- [6] ISO 23247-3, *Automation systems and integration — Digital Twin framework for manufacturing—Part 3: Digital representation of manufacturing elements*, 2021.
- [7] ISO 23247-4, *Automation systems and integration — Digital twin framework for manufacturing — Part 4: Information exchange*, 2021.
- [8] ISO 23952, *Automation systems and integration — Quality information framework (QIF) — An integrated Model for manufacturing quality information*, 2020.
- [9] ISO/IEC 11179-6, *Information technology — Metadata registries (MDR) - Part 6: Registration*, 2023.
- [10] SAE International AIR 7161, “*Guidance in Digital Thread data standards Enablement, Monitoring and Quantification with Digital thread Index*”, Venkata and Rencher, 2024.
- [11] Grieves, M. and J. Vickers, “*Digital Twin: Mitigating Unpredictable, Undesirable Emergent Behavior in Complex Systems, in Trans-Disciplinary Perspectives on System Complexity*”, 2016.
- [12] IETF RFC 4122, *A Universally Unique IDentifier (UUID) URN Namespace*, 2005.