

Collaborative process planning

- Cutting recommendations
 - Tool specification
 - Strategy parameters (values – range and optimal)
 - Technology parameters (values – range and optimal)
- Recommendation context
 - User specific or archetype feature
 - Material specification
 - Machine specification
 - Stability condition

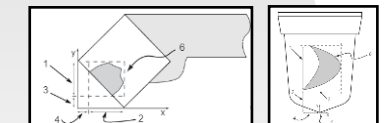
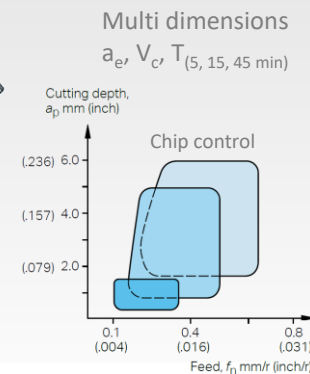
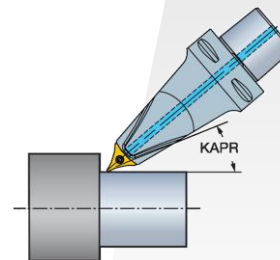
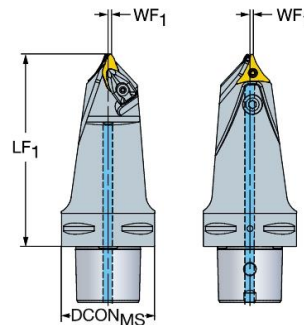
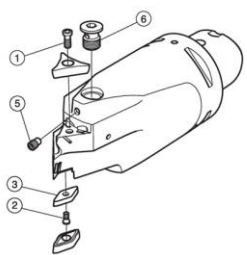
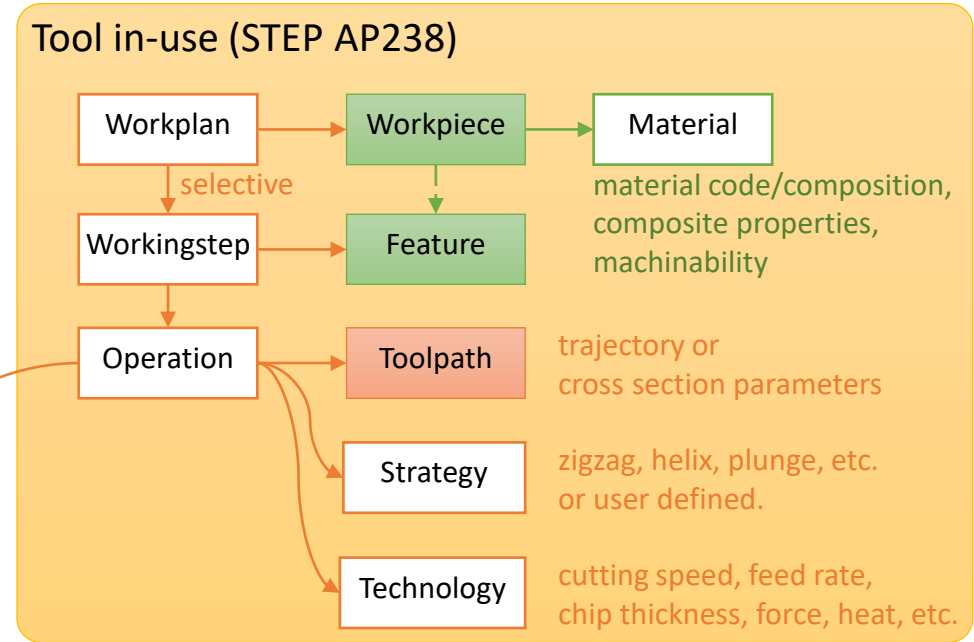
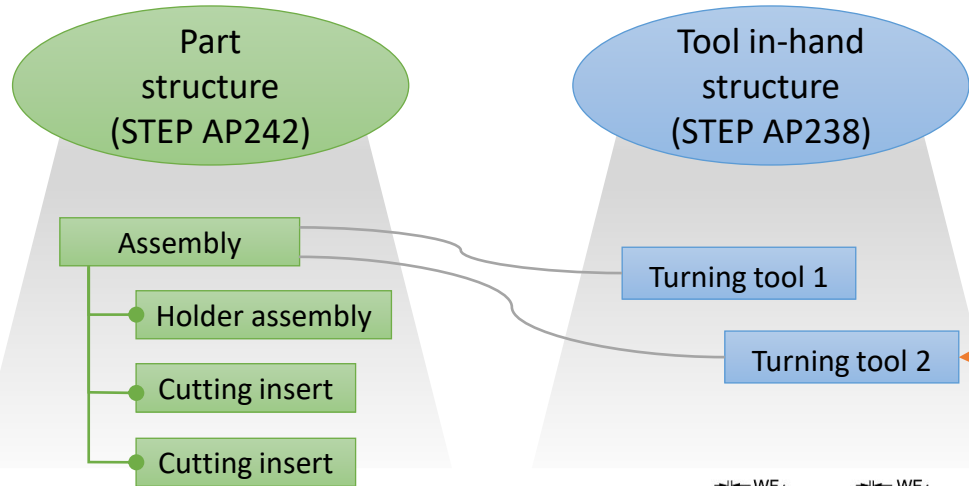
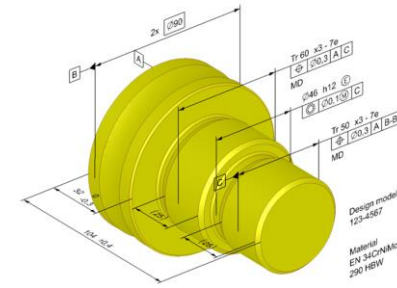

Operation window 2

Operation window 1

- Cutting speed: 120 (90 - 130) m/min
- Chip thickness (and mill engagement): 0,03 - 0,04 mm (51–100%)
0,04 - 0,07 mm (0–50%)