

# ISO 23247 Digital Twin Use case Testing

Results of August 18 Conference call

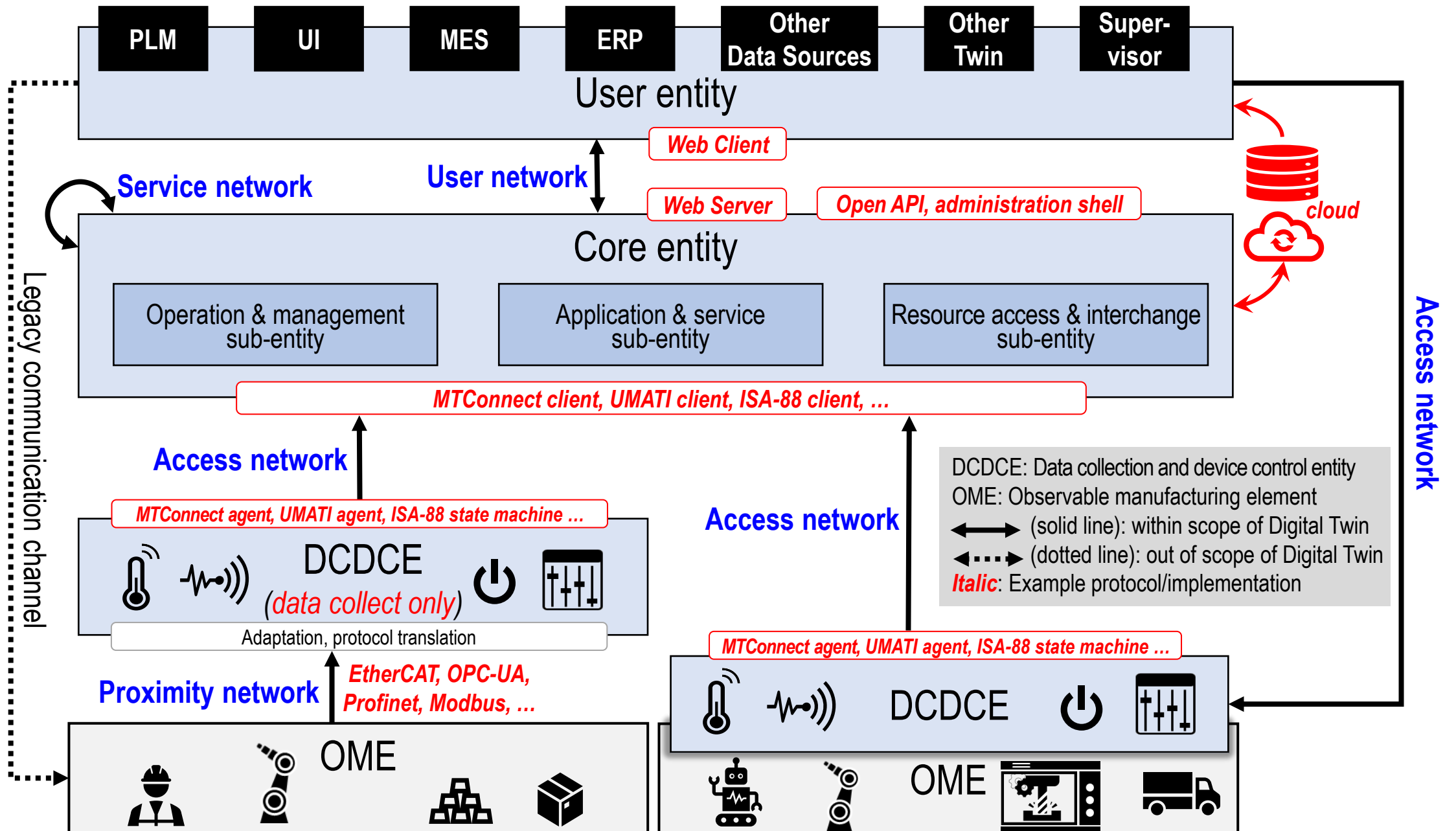

# Use Case 1 – flexible schedule for robot drill & fill

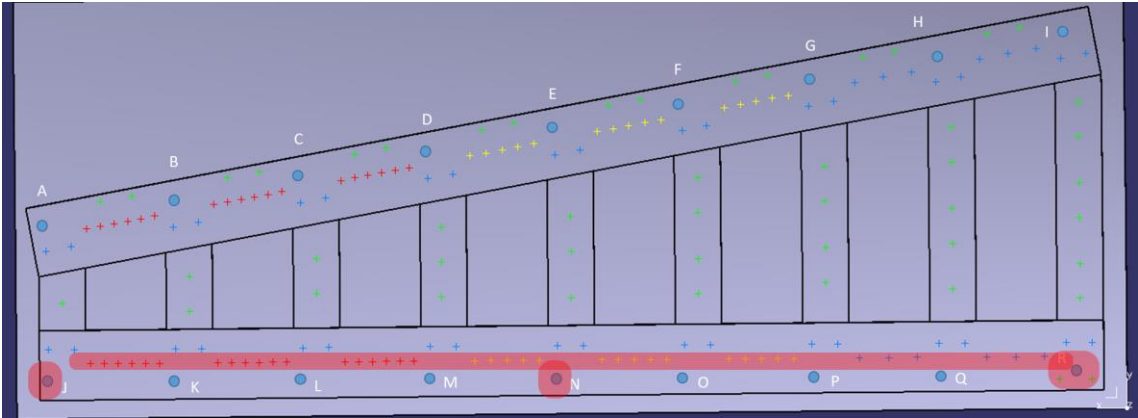
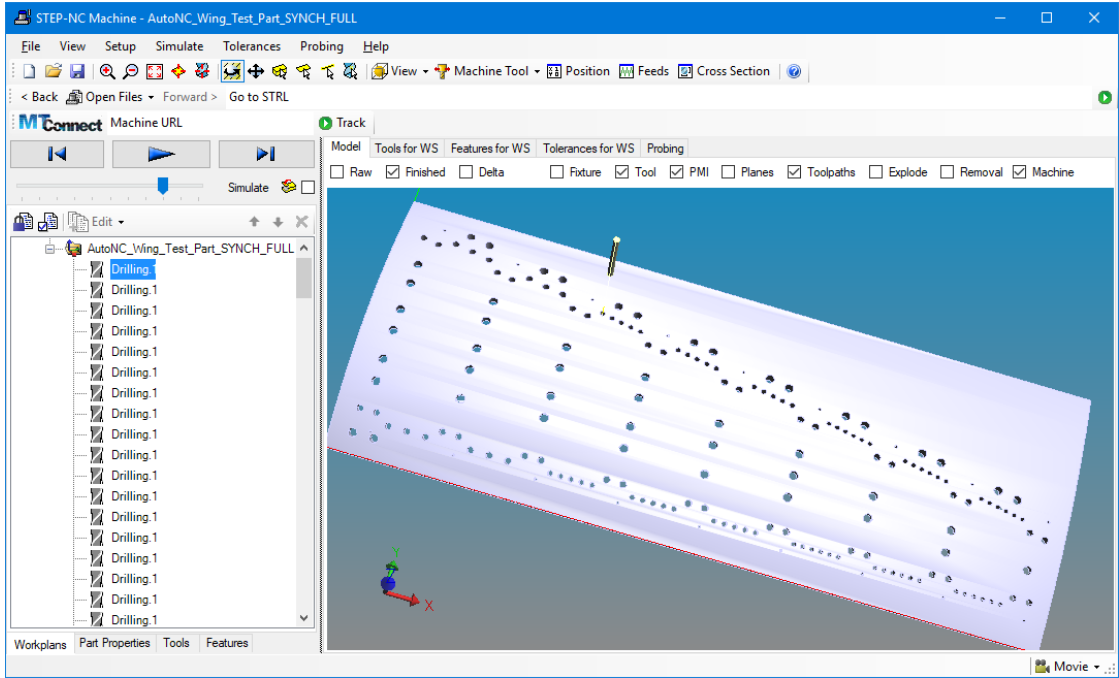

On-shoring can increase by 50%

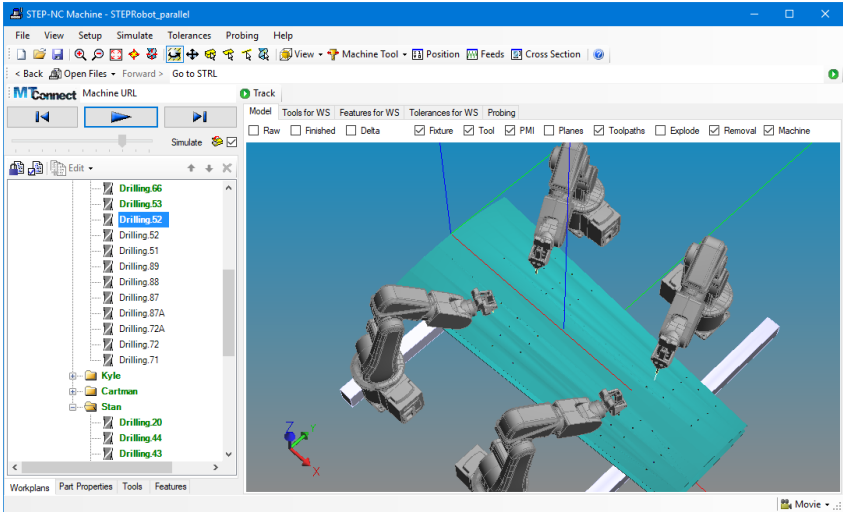

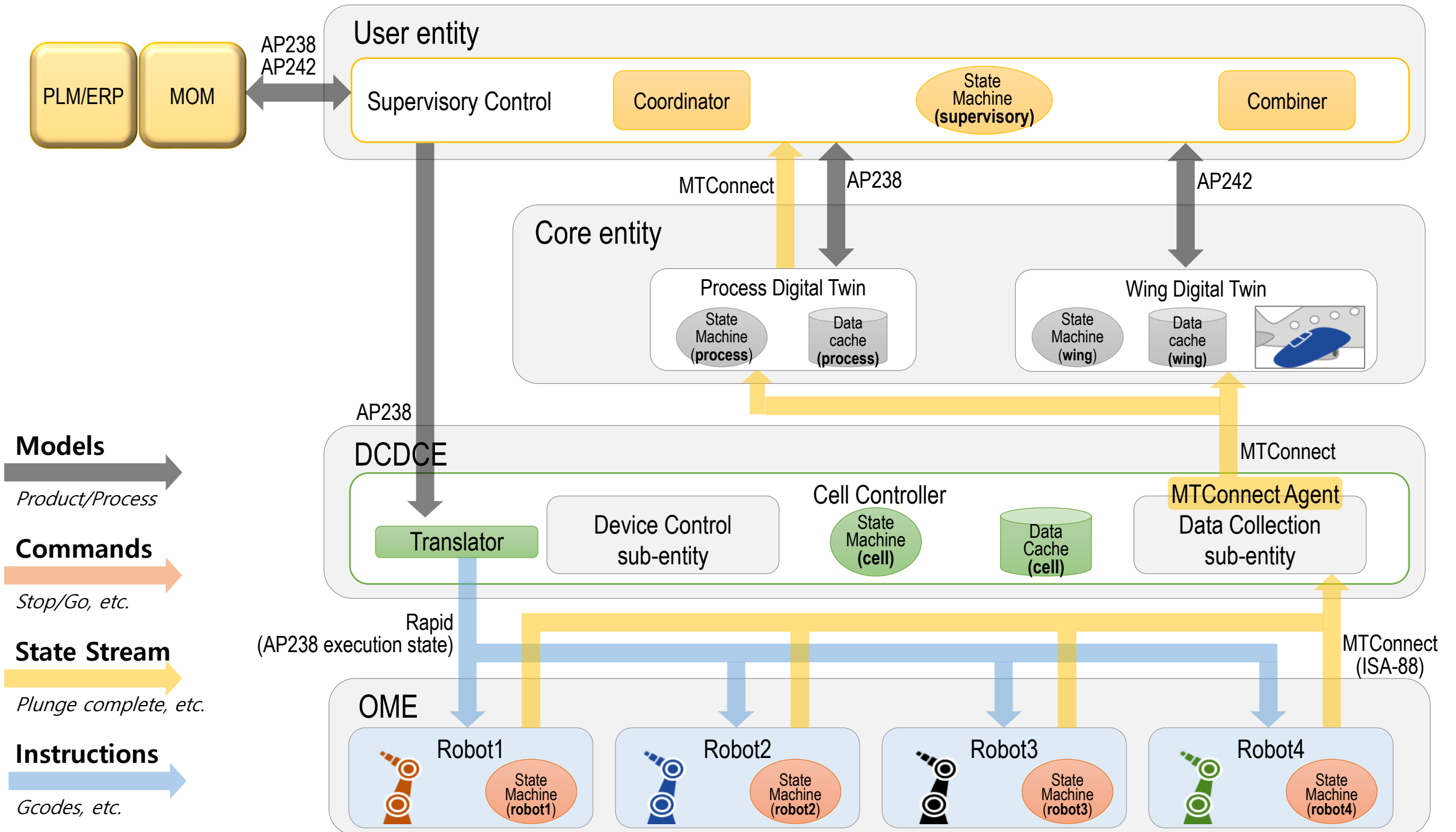

# Assembly/Process Flow

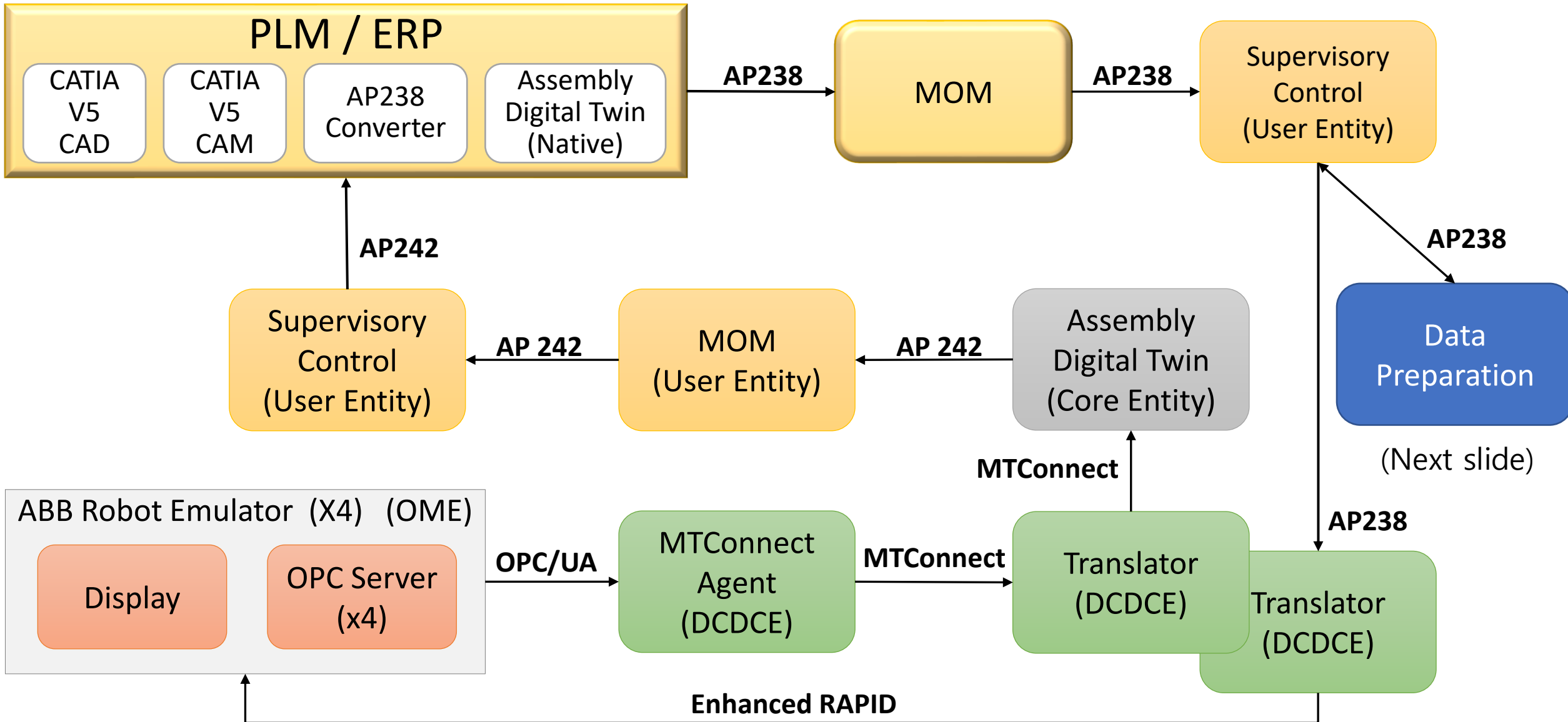

# MTConnect

<Events>

```
<WorkingStepDataSet dataItemId="I22a766e4465"  
    timestamp="2020-07-28T20:27:06.147161Z"  
    name="WorkingStep" sequence="179" count="2">  
  <Entry key="NAME">Drilling.2</Entry>  
  <Entry key="UUID">b062b09d-c75e-4509-b058-f533fc3121cb</Entry>  
</WorkingStepDataSet>  
<FeatureDataSet dataItemId="I95ded582189"  
    timestamp="2020-07-28T20:27:06.147161Z"  
    name="Feature" sequence="180" count="2">  
  <Entry key="NAME">Hole.101</Entry>  
  <Entry key="UUID">7ba2387a-5122-471d-9e62-f4dd978dd916</Entry>  
</FeatureDataSet>
```

</Events>

[https://github.com/mtconnect/iso\\_digital\\_twin\\_adapter](https://github.com/mtconnect/iso_digital_twin_adapter)

# Data Preparation

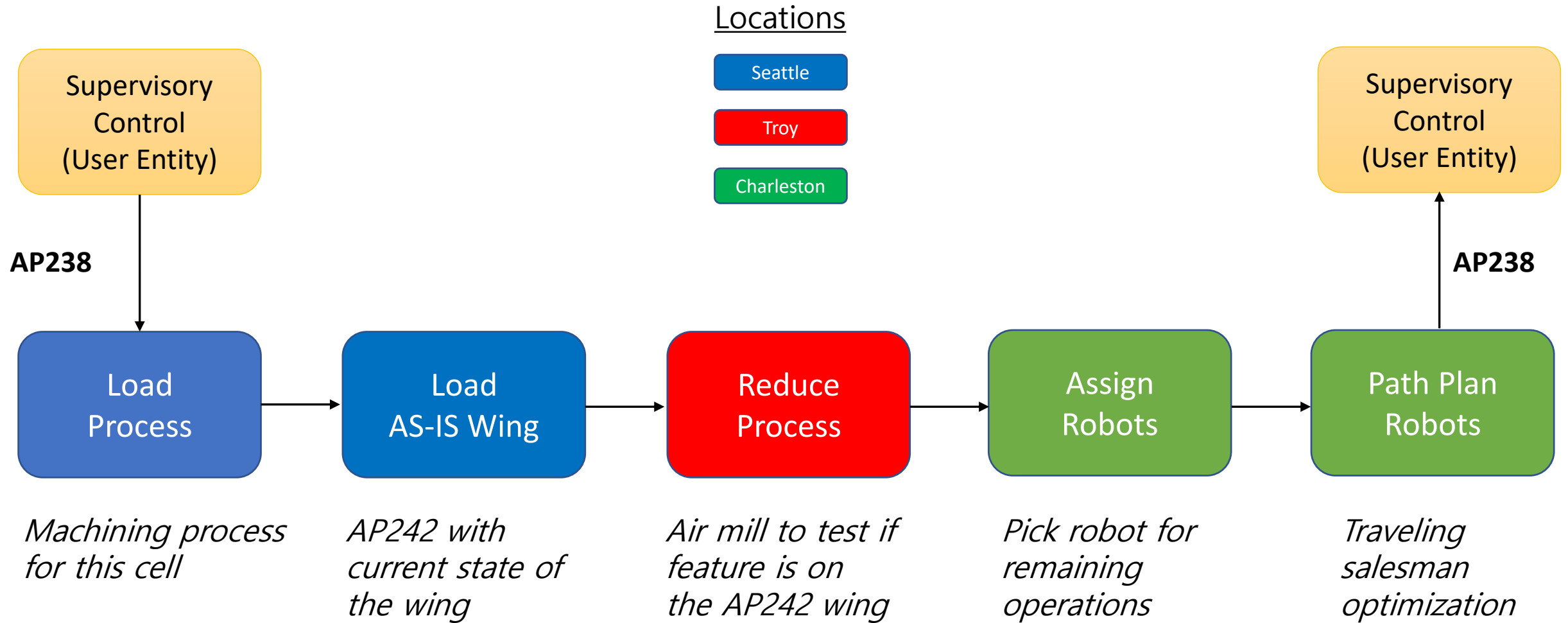

# Hole detection using AP242

Two holes

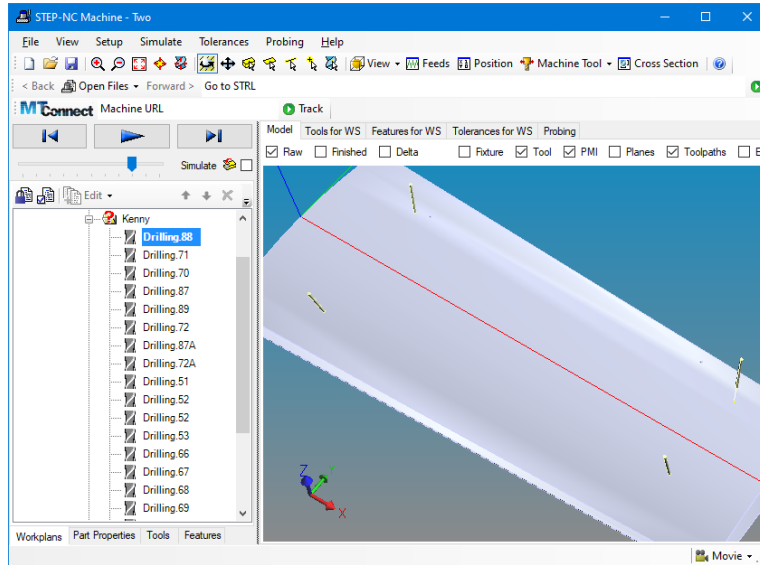

Eight holes

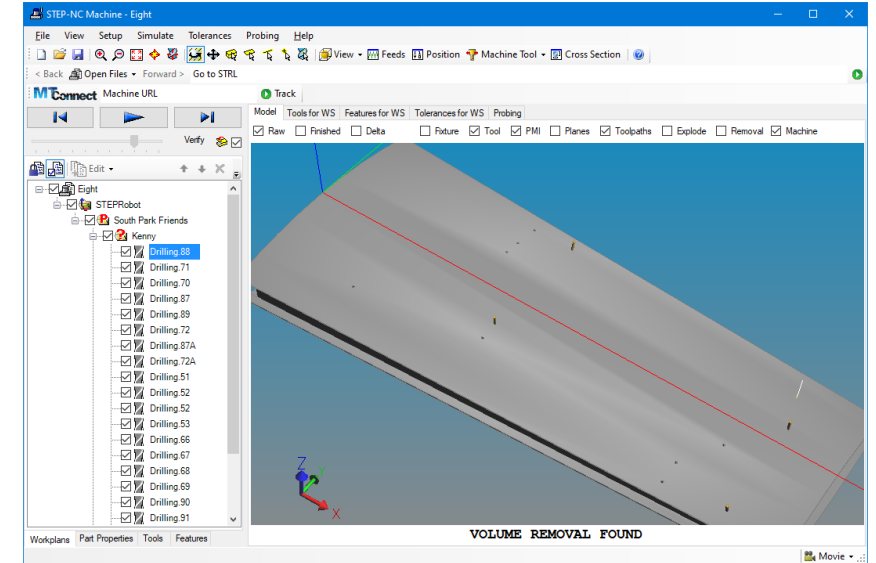

Two holes found

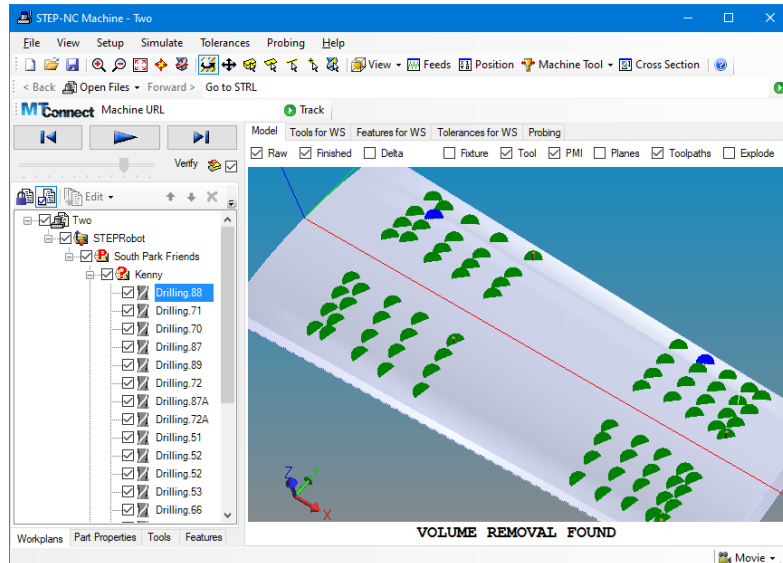

Eight holes found

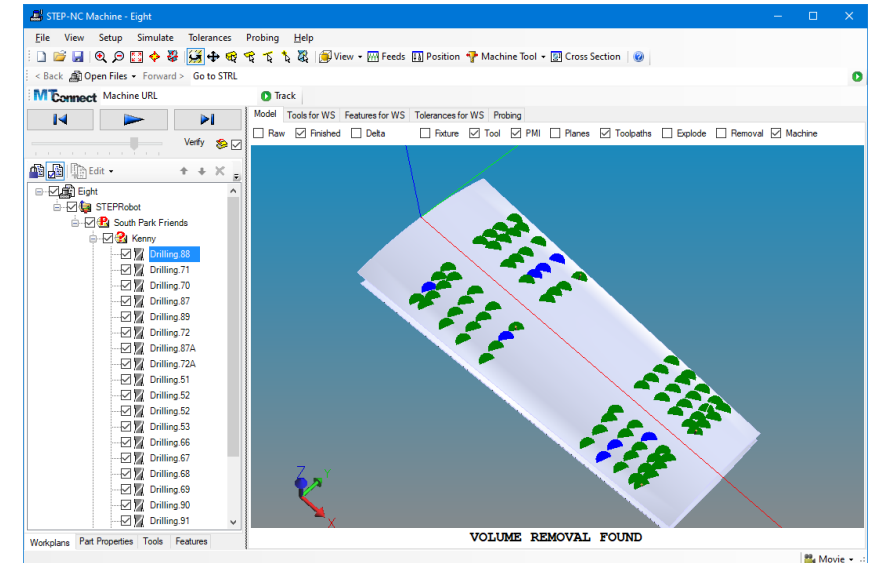



# Digital Twin process model

<https://stepmfg.github.io/ap238e2/data/clause5.htm#fig-twinmodel>

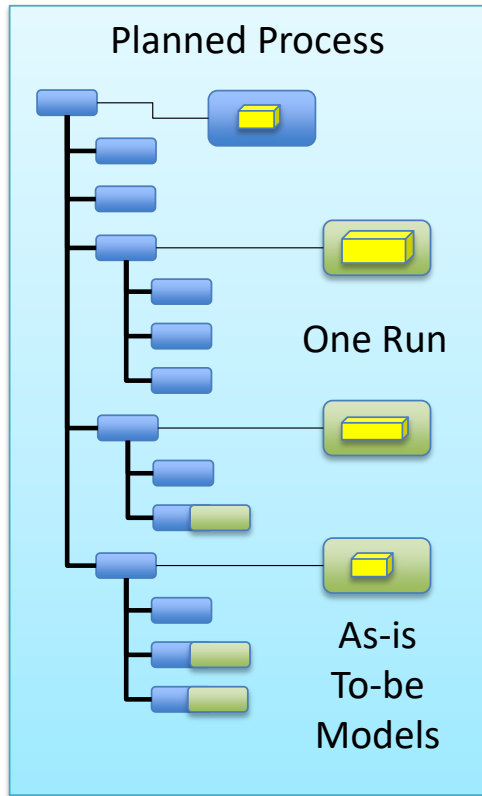

*Model process state using new attributes*

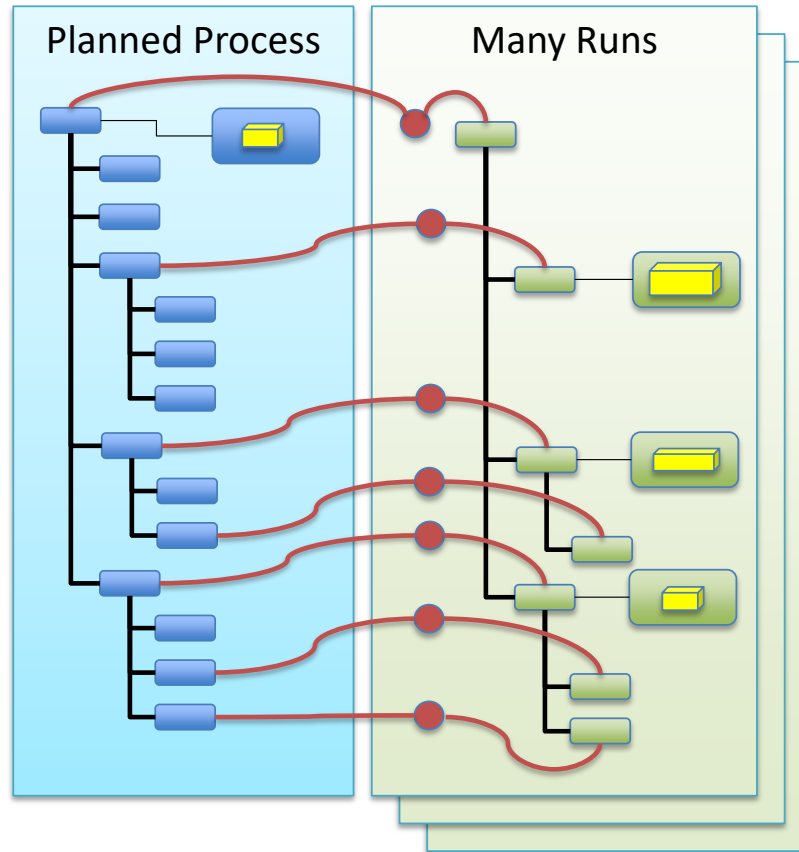

*Link runs using Part 21 Edition 3*

**ENTITY executable**

```
[ ... other attributes omitted ... ]  
twin_source: OPTIONAL twin_source_enum;  
twin_plan: OPTIONAL executable;  
twinning_start : OPTIONAL Date_time;  
twinning_end :   OPTIONAL Date_time;  
twinning_log : LIST [0:?] log_record;  
in_cut_time : OPTIONAL Duration;  
END_ENTITY;
```

```
TYPE twin_state_enum = ENUMERATION OF (simulated, machined); END_TYPE;
```

**ENTITY log\_record**

```
description : STRING;  
date_time : Date_time;  
END_ENTITY;
```

*Executable is supertype of all processes.*

*Definition above shows new attributes for Edition 2*

- Hole.1 (ROUND\_HOLE)
- Hole.2 (ROUND\_HOLE)
- Hole.3 (ROUND\_HOLE)
- Hole.4 (ROUND\_HOLE)
- Hole.5 (ROUND\_HOLE)
- Hole.6 (ROUND\_HOLE)**
  - Depth = 0.39 in
  - Diameter = 0.19 in
  - Position = (11.354, 1.149, 0.34) in
  - Bottom type = CONICAL\_HOLE\_BOTTOM
  - Tools
    - Tool - T6, D=0.19, L=1.96850393700787
  - Workingsteps
    - Drilling.6
    - Entity = 17463 Started = 2020-07-21T09:16:29.701-04:00
    - Ended =
    - Elapsed time =
- Hole.7 (ROUND\_HOLE)
- Hole.8 (ROUND\_HOLE)
- Hole.9 (ROUND\_HOLE)
- Hole.10 (ROUND\_HOLE)
- Hole.11 (ROUND\_HOLE)
- Hole.12 (ROUND\_HOLE)
- Hole.13 (ROUND\_HOLE)
- Hole.14 (ROUND\_HOLE)
  - Depth = 0.387 in
  - Diameter = 0.19 in
  - Position = (7.554, 1.139, 0.372) in
  - Bottom type = CONICAL\_HOLE\_BOTTOM
  - Tools
    - Tool - T6, D=0.19, L=1.96850393700787
  - Workingsteps
    - Drilling.14
    - Entity = 17391 Started = 2020-07-21T09:16:01.341-04:00
    - Ended = 2020-07-21T09:16:25.616-04:00
    - Elapsed = 24 seconds, 275 milliseconds
- Hole.15 (ROUND\_HOLE)
- Hole.16 (ROUND\_HOLE)
- Hole.17 (ROUND\_HOLE)
- Hole.18 (ROUND\_HOLE)

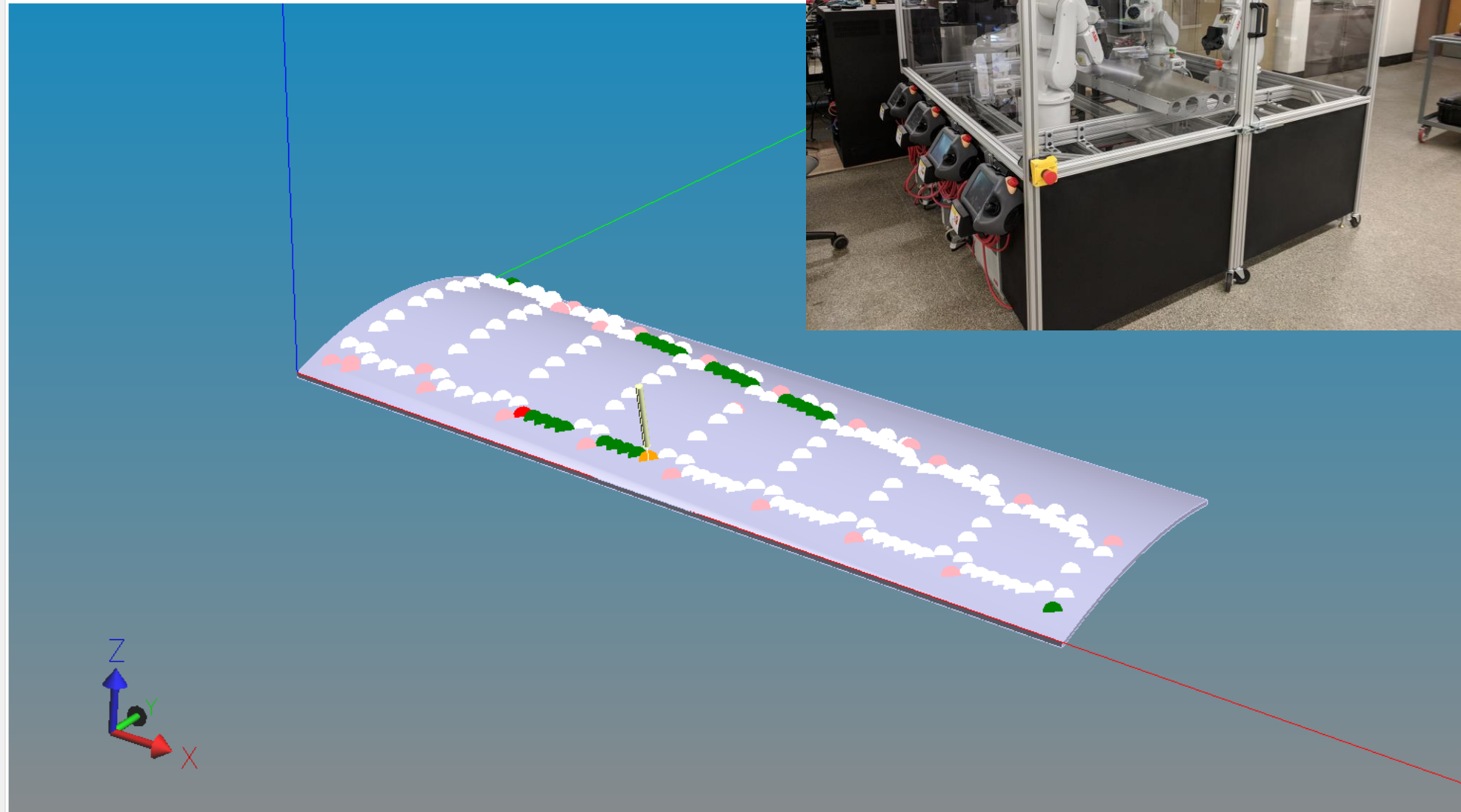

White (ready) Green (complete) Orange (in process) Red (error) Pink (missing data)

# Schedule

	☰	▾ CAD /CAM	25 days	Mon 7/6/20	Sat 8/8/20	
/	★	CATIA V5 -> AP238	0 days	Mon 7/20/20	Mon 7/20/20	
	★	Supervisory Control	6 days	Mon 7/20/20	Mon 7/27/20	
/	★	AP238 -> Rapid	6 days	Mon 7/20/20	Mon 7/27/20	
/	★	Setup OPC/UA Server	16 days	Mon 7/6/20	Mon 7/27/20	
/	★	Define OPC/UA Tags	3 days	Mon 7/20/20	Wed 7/22/20	
	★	Define MTConnect Tags	3 days	Thu 7/23/20	Mon 7/27/20	30
	★?	Setup MTConnect Adapter/Agent				
🚨	★	MTConnect -> Digital Twin	7 days	Fri 7/31/20	Sat 8/8/20	31
	☰	▾ State Machine	6 days?	Thu 7/23/20	Thu 7/30/20	
🚨	★	Define OPC/UA Tags	3 days	Thu 7/23/20	Mon 7/27/20	30
	★	Define MTConnect Tags	3 days	Tue 7/28/20	Thu 7/30/20	35
	★?	Map MTConnect to PackML				
	★?	PackML Client				

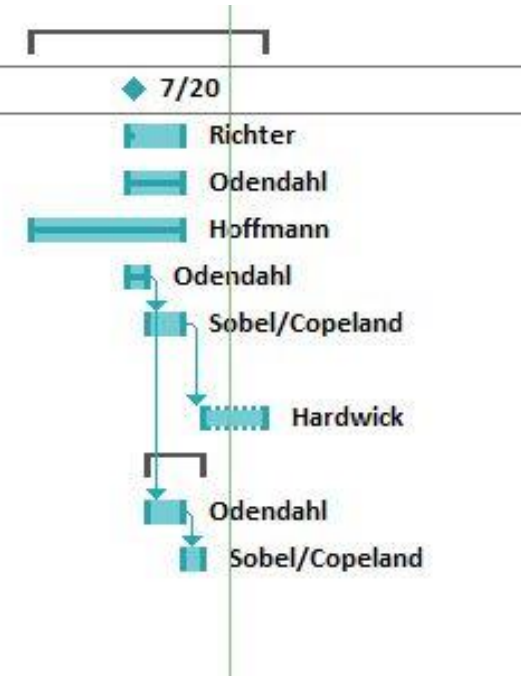



# Use Case 2 – weight reduction

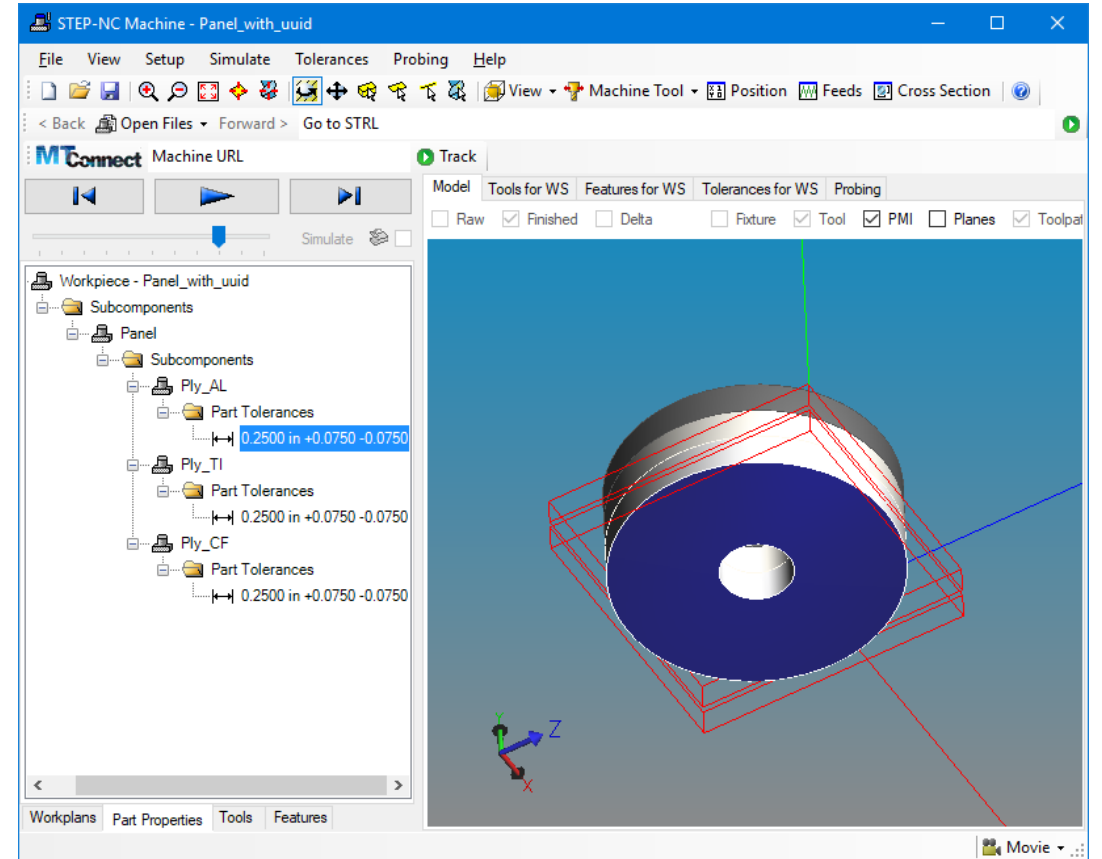
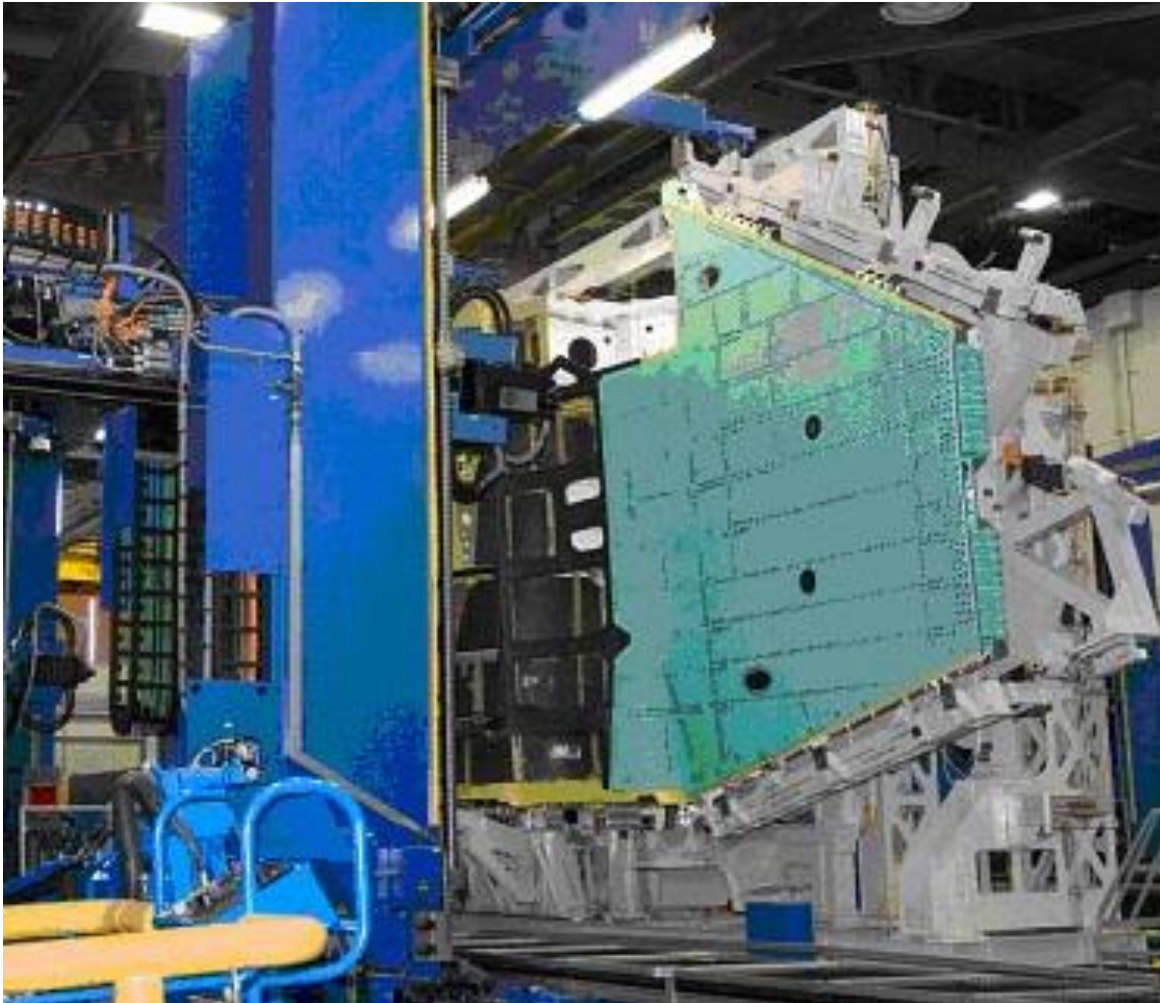

Exact match of fastener to hole depth  
can reduce weight by 500lb

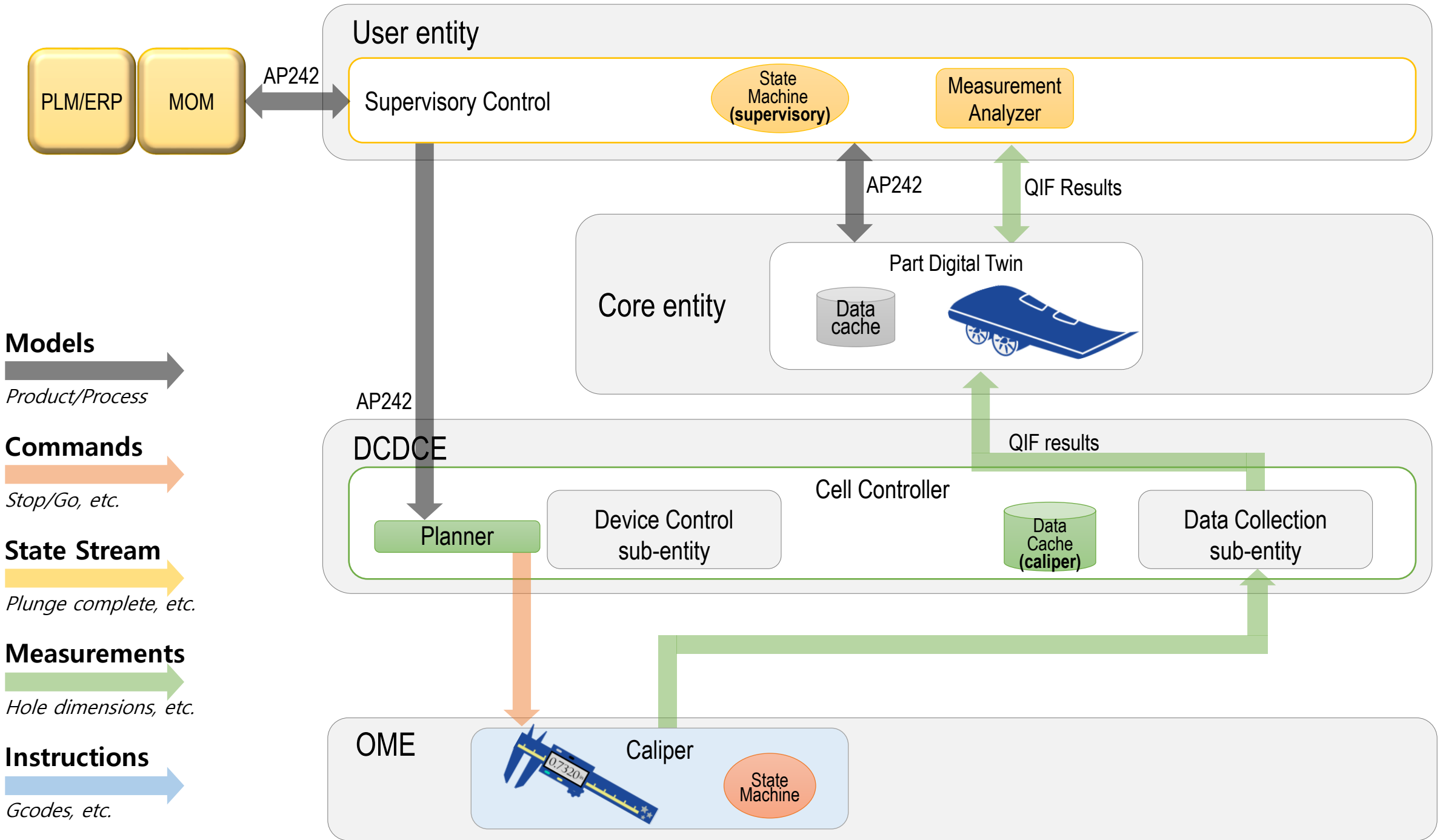

# Measurement samples

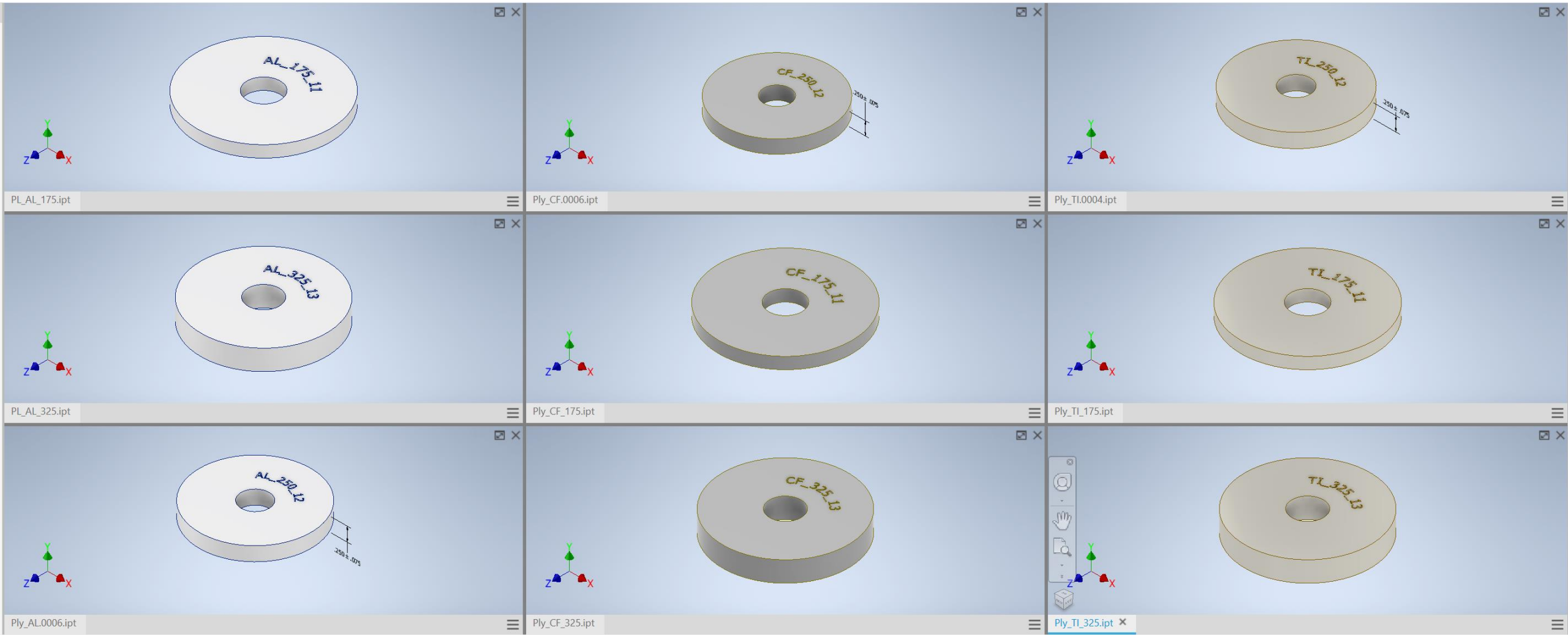

# AL\_250\_Results.qif

```
<MeasurementResults id="13">
  <MeasuredCharacteristics>
    <CharacteristicMeasurements n="1">
      <DistanceBetweenCharacteristicMeasurement id="14">
        <Status>
          <CharacteristicStatusEnum>PASS</CharacteristicStatusEnum>
        </Status>
        <CharacteristicItemId>6</CharacteristicItemId>
        <TimeStamp>2020-08-14T11:02:48.9811824-05:00</TimeStamp>
        <Value>0.3191</Value>
      </DistanceBetweenCharacteristicMeasurement>
    </CharacteristicMeasurements>
  </MeasuredCharacteristics>
  <InspectionStatus>
    <InspectionStatusEnum>PASS</InspectionStatusEnum>
  </InspectionStatus>
  <ActualComponentIds n="1">
    <Id>15</Id>
  </ActualComponentIds>
</MeasurementResults>

  <CharacteristicItems n="1">
    <DistanceBetweenCharacteristicItem id="6">
      <Description>AL_250.Thickness</Description>
      <Name>Thickness</Name>
      <CharacteristicDesignator>
        <Designator>25</Designator>
        <UUID>6a45ec6c-3b4e-4b17-ae85-aada5131a8ec</UUID>
      </CharacteristicDesignator>
      <CharacteristicNominalId>4</CharacteristicNominalId>
    </DistanceBetweenCharacteristicItem>
  </CharacteristicItems>
```

<b>Task</b>	<b>23247 Use Case Reference</b>	<b>Completion Date</b>	<b>Completion %</b>	<b>Status</b>
Define Use Case		16-Mar-20	100%	Complete
Document Use Case		22-Apr-20	100%	Complete
Author MBDs	PLM/ERP	14-May-20	100%	Complete
Export AP242 Nominals	User Entity	14-May-20	100%	Complete
Export QIF Plan	DCDCE	14-May-20	100%	Complete
Measure Parts (key-in)	OME	14-May-20	100%	Complete
Export QIF Measured Results	DCDCE	15-May-20	100%	Complete
Import QIF Measured Results	Core Entity	20-May-20	100%	Complete
Assemble AP242 Digital Twin	User Entity	20-May-20	100%	Complete
Revise Use Case	OME	30-Jun-20	100%	Complete
Receive Fabricated Parts		5-Aug-20		
Measure Parts (as-built)	OME	5-Aug-20		
Internal Rehearsal	OME	7-Aug-20		
Export QIF Measured Results	DCDCE	7-Aug-20		
Import QIF Measured Results	Core Entity	10-Aug-20		
Assemble AP242 Digital Twin	User Entity	14-Aug-20		
Evaluate As-built Digital Twin	PLM/ERP	28-Aug-20		Rehearsal



# Use Case 3 – tool life optimization

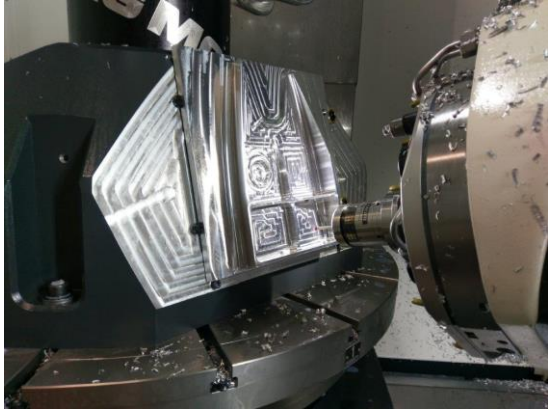

Machine parts

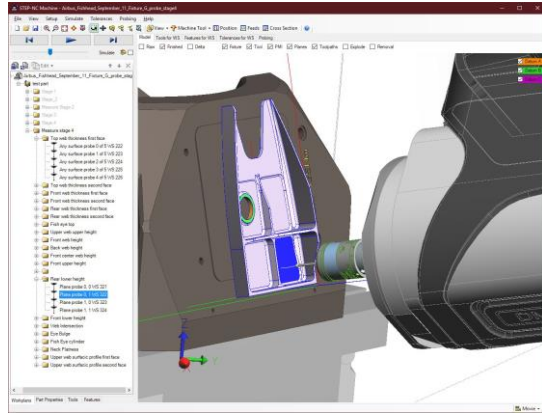

Monitor tool diameter

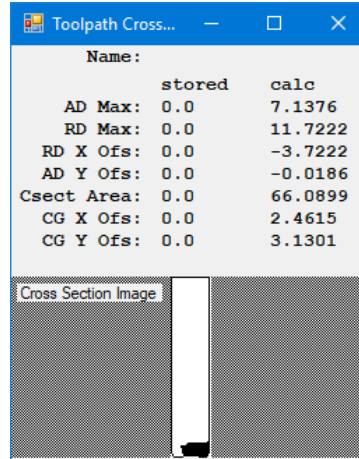

Compute tool engagement

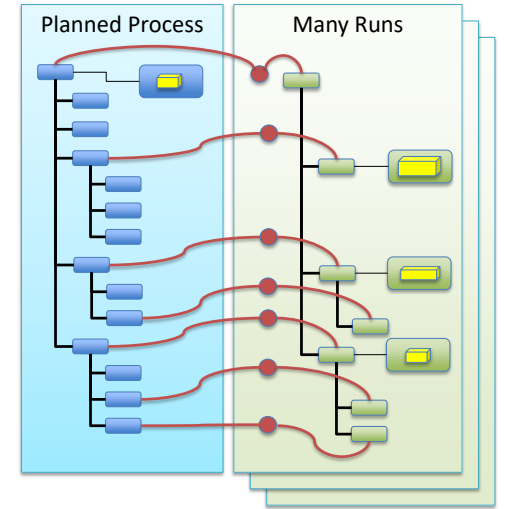
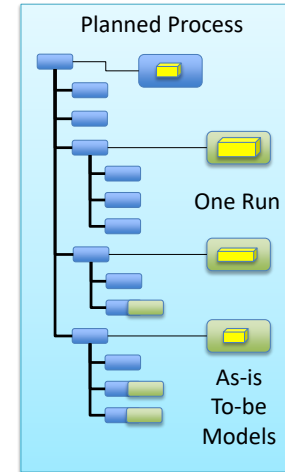

Store linked data

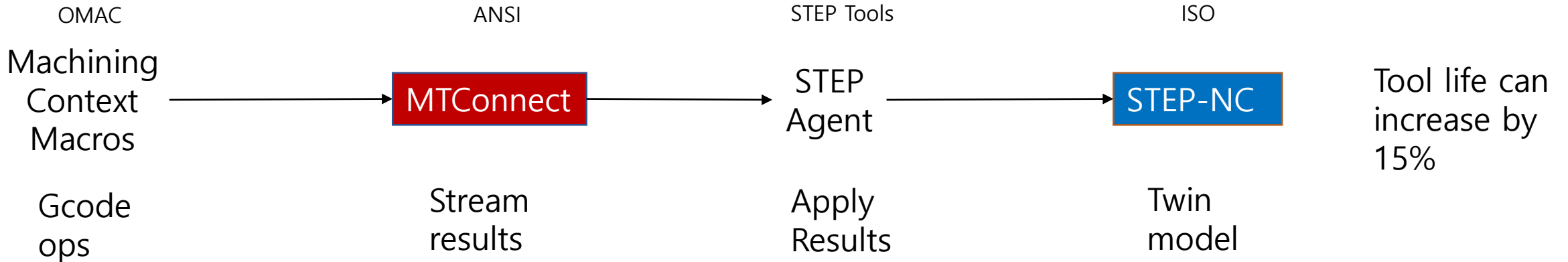

# MQTT data

```
test_data = {"projectRelease":"empty","productID": "Boxy_3-Axis",  
,"featureName":"empty","toolClass":"empty", "workingStepName"  
:"OP 3 Fine Milling Datum D, E, F and G", "workingStepDescriptio  
n":"empty", "programVersion":"empty","endofcycle":"empty","pro  
jectStatus":"empty", "workingStepType":"empty", "toolID":"a410a  
ecc-cdd0-4cc4-890e-cdbbca53ee40", "productVersion":"empty","to  
olDescription":"empty","featureType":"empty", "workingStepID":"  
empty","operationID":"empty","operationType":"empty", "startofc  
ycle":"2019-04-04 08:46:02.896","projectID":"empty", "programI  
D":"Boxy_3-Axis_Machining_Setup_1.stpnc", "featureID":"empty","  
toolName":"empty"}
```

ISO 23247-4 Figure A.3

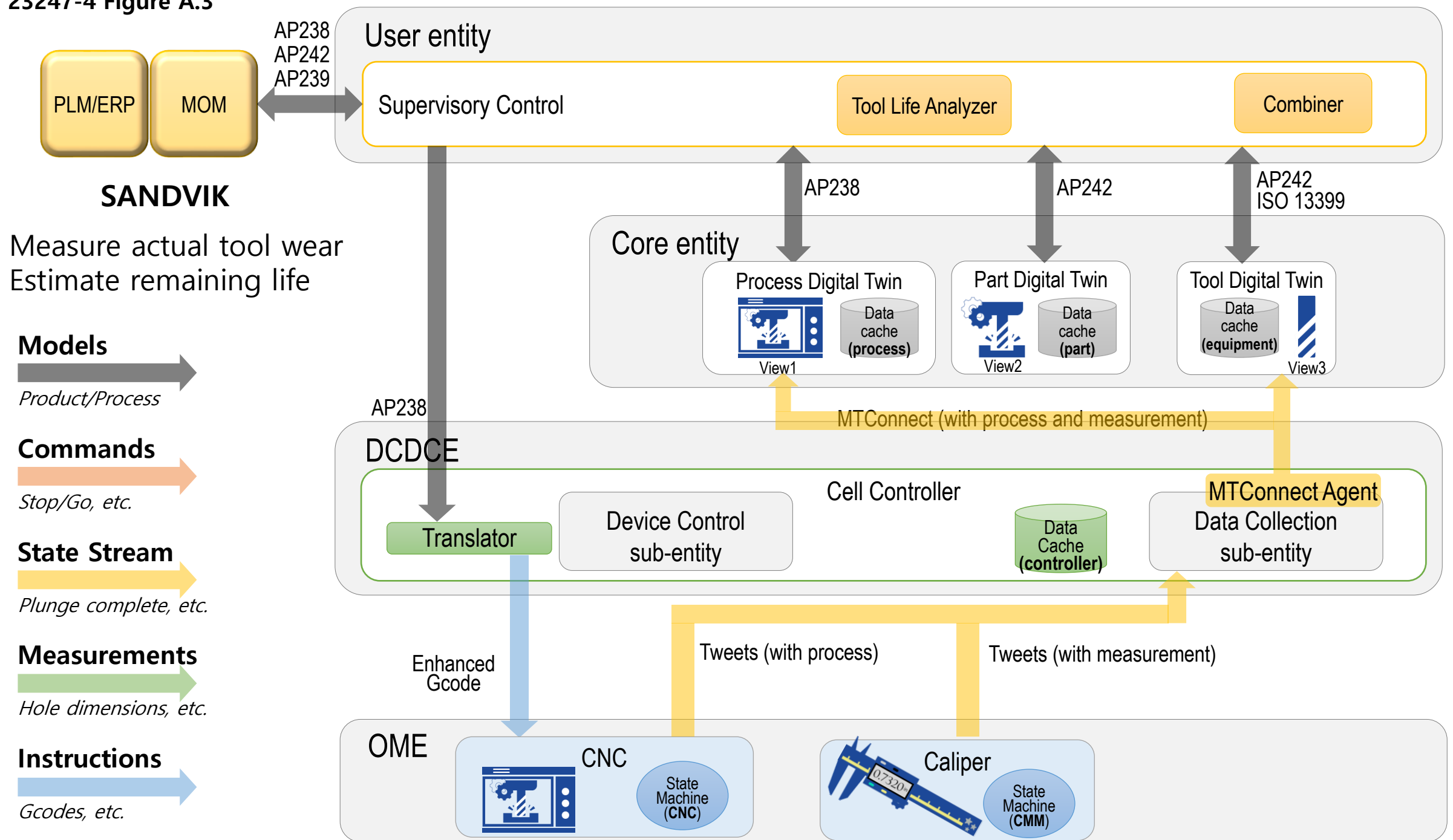

Tool life optimization  
-demonstration of feedback  
from CNC and Caliper

team and plan set up  
(June 30th)

Bengt Olsson, Sandvik Coromant

- team leader
- tooling and process models

Darya Botkina, KTH

- enrichment of incoming G-code
- CNC and Caliper
- out going tweets

Will Sobel, Vimana

- Agent converting tweets to MTConnect stream

Martin Hardwick, StepTools

STEP-NC Machine

- convert process to G-code
- read MTConnect stream of process tweets with actual context from CNC
- read MTConnect stream of measurement tweets with actual context from Caliper
- combine planned with received

Jonas Rosén, Eurostep

- life cycle management
  - actual process
  - actual tools
  - actual parts

selection of process  
(July 3rd)

process

Bengt and Darya

parts

Darya

tools

Bengt

process defined  
(Aug 4th)

- STEP-NC Machine
- CNC

MTConnect agent  
for output of  
"tweet streams"  
(Aug 11th)

Create agent for process tweets  
and measurement tweets

Will

Install agent at KTH

Darya

reading of MTConnect  
"tweet streams"  
(August 11th)

- set up STEP-NC Machine to read tweet streams
- determine real in-cut time (store for "this run")

Martin

set up "life cycle manager" to read tweet streams

Jonas

Dry run  
(August 18th)

CNC "process tweets"

- CNC to STEP-NC Machine to AP238
- CNC to "life cycle manager" to AP239

Caliper "part measure tweet"

- Caliper to STEP-NC Machine to QIF/AP238
- Caliper to "life cycle manager" to AP239

Demonstration ready  
(August 25th)

Run process

CNC at KTH

output MTConnect stream

Measure part

Caliper at KTH

output MTConnect stream

Combine information

STEP-NC Machine at StepTools

- read MTConnect streams
- "real time" viewing
- output as AP238

Manage lifecycle at Eurostep

- read MTConnect streams
- output as AP239

# Proposed Demonstration Schedule

- September 1 – Dress rehearsal for Use Case 2
- September 8 – Dress rehearsal for Use Case 3
- September 15 – Dress rehearsal for Use Case 1
- September 22 – Final planning for public demonstration
- September 29 – One hour demonstration of the three use cases

# Action items for next week

- Use Case 2
  - Martin to process QIF results files
  - Larry to script the demos
- Use Case 1
  - MTConnect to discuss use cases on Thursday and give feedback