

ISO 23247 Digital Twin Use case Testing

Results of August 11 Conference call

ISO 23247-4 Figure A.1

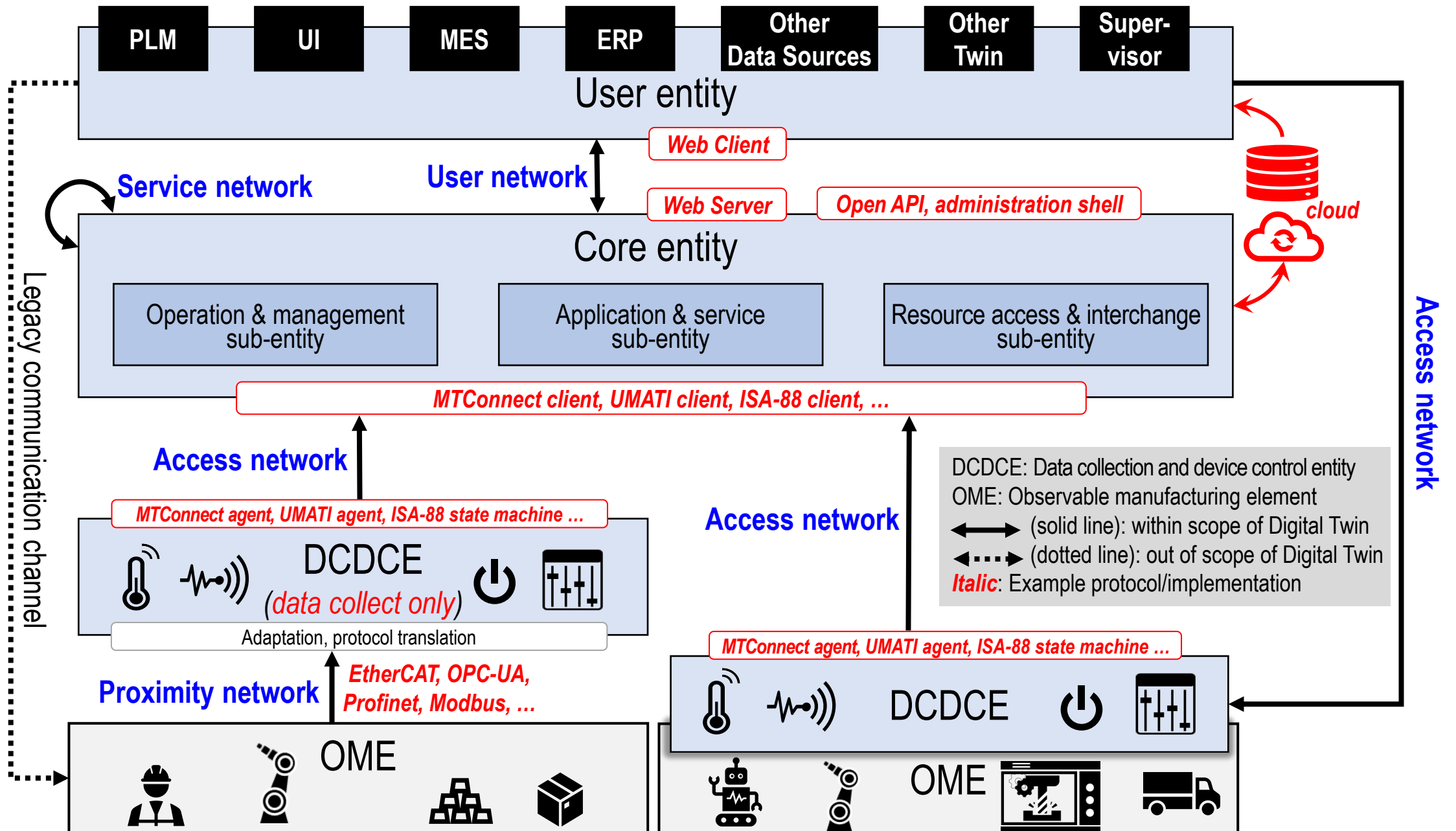

Use Case 1 – flexible schedule for robot drill & fill

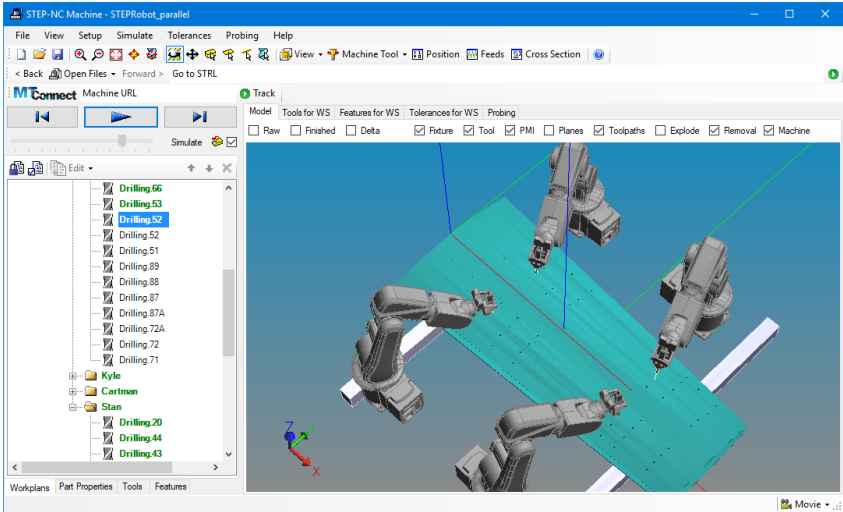
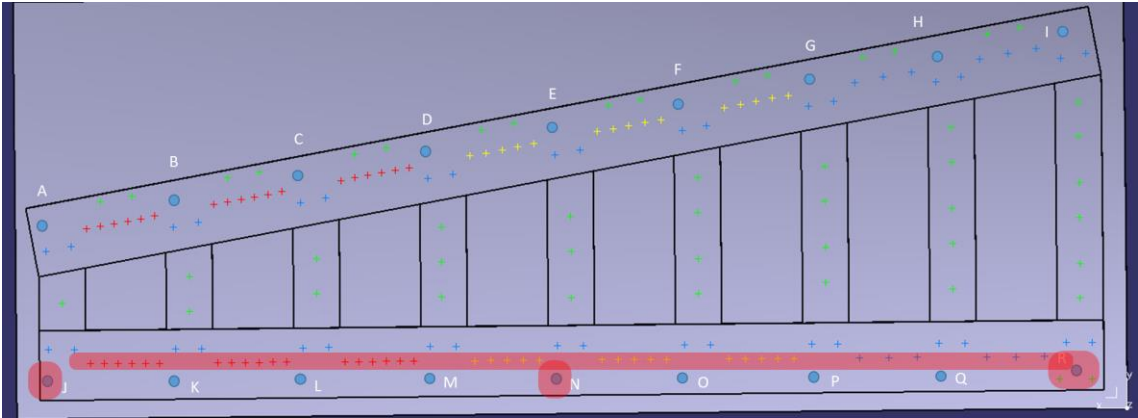
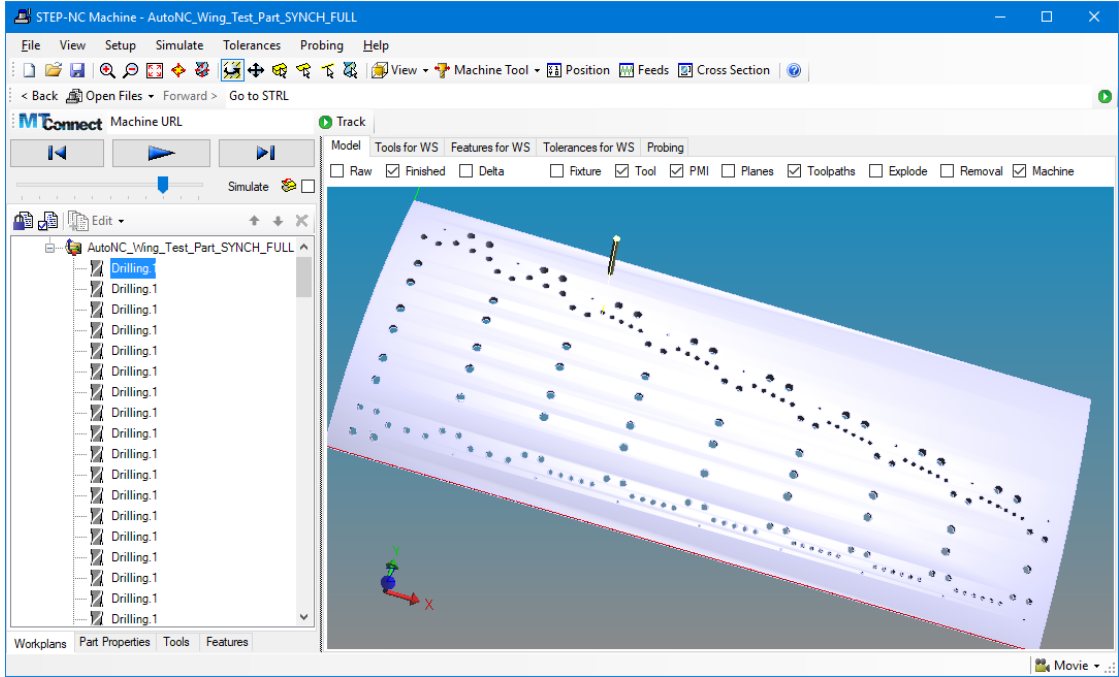

On-shoring can increase by 50%

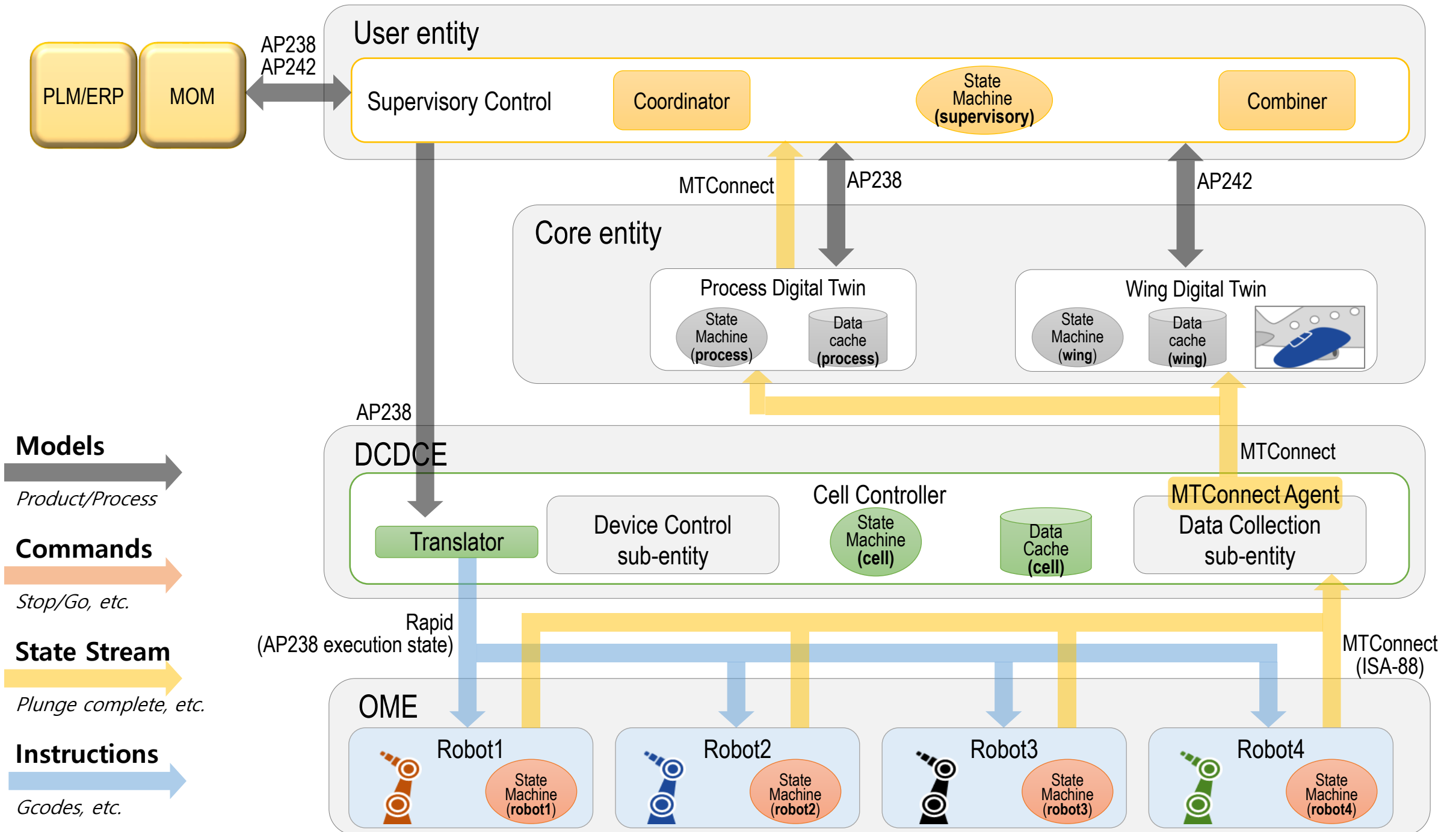

Assembly/Process Flow

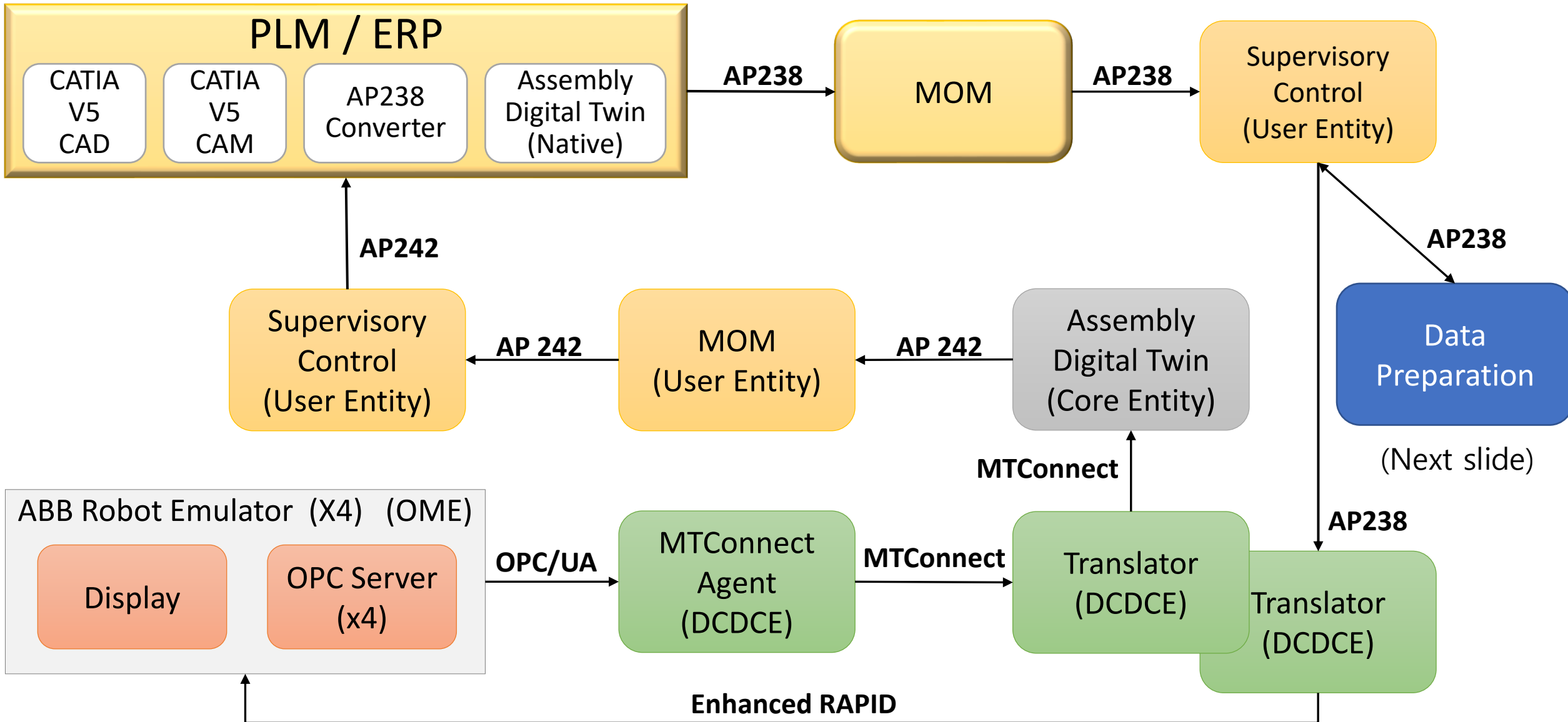

MTConnect

<Events>

```
<WorkingStepDataSet dataItemId="I22a766e4465"  
    timestamp="2020-07-28T20:27:06.147161Z"  
    name="WorkingStep" sequence="179" count="2">  
  <Entry key="NAME">Drilling.2</Entry>  
  <Entry key="UUID">b062b09d-c75e-4509-b058-f533fc3121cb</Entry>  
</WorkingStepDataSet>  
<FeatureDataSet dataItemId="I95ded582189"  
    timestamp="2020-07-28T20:27:06.147161Z"  
    name="Feature" sequence="180" count="2">  
  <Entry key="NAME">Hole.101</Entry>  
  <Entry key="UUID">7ba2387a-5122-471d-9e62-f4dd978dd916</Entry>  
</FeatureDataSet>
```

</Events>

https://github.com/mtconnect/iso_digital_twin_adapter

Data Preparation

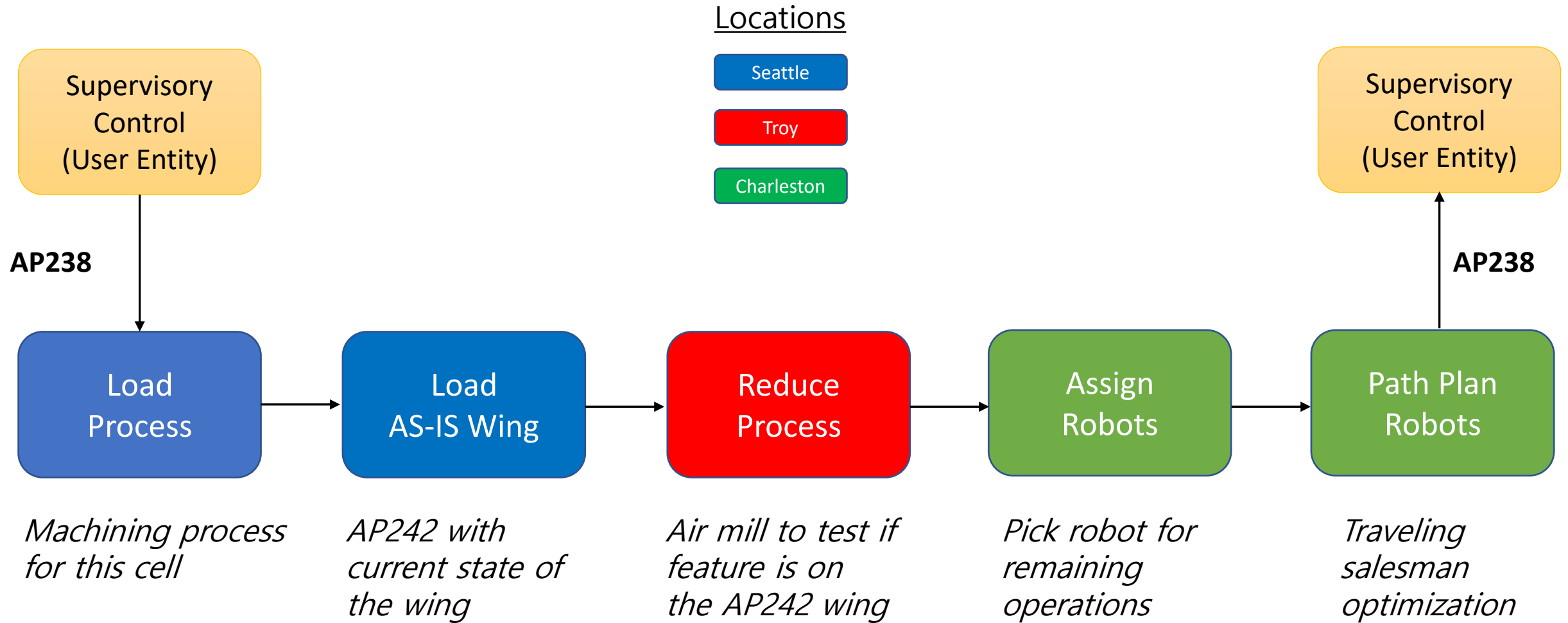

Hole detection using AP242

Two holes

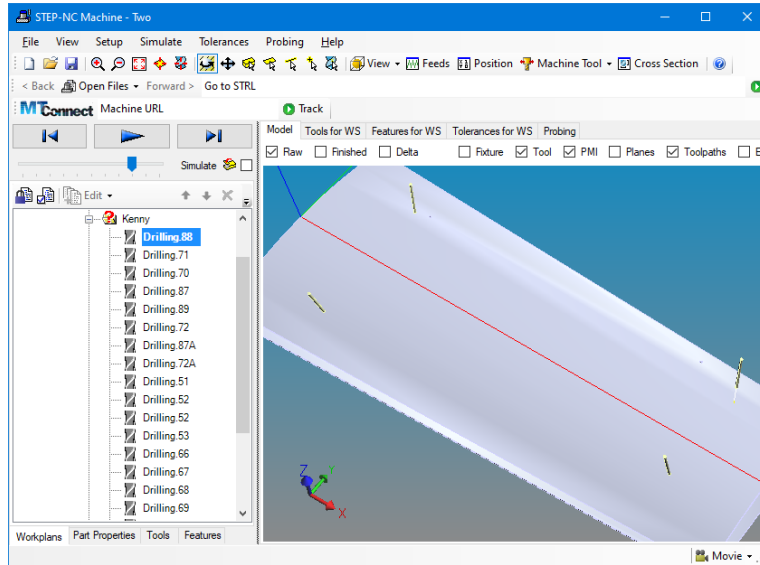

Eight holes

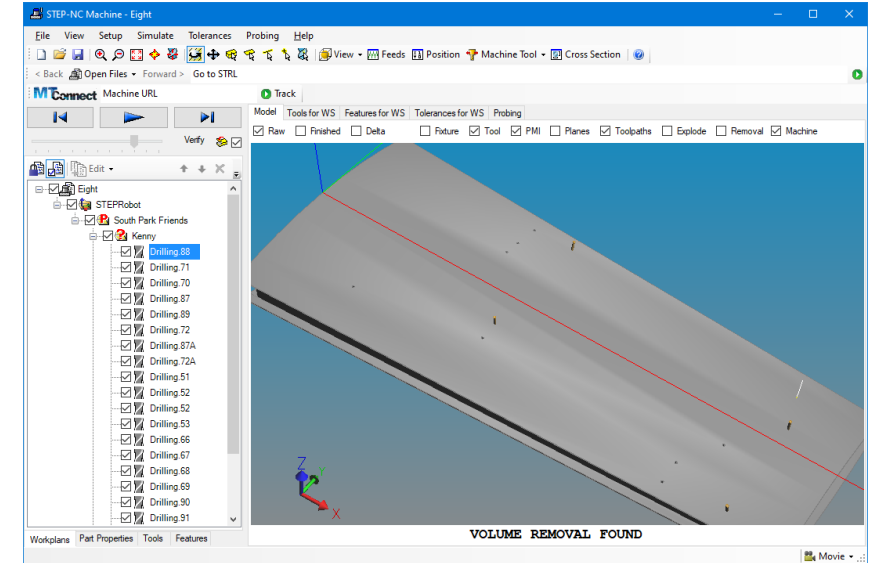

Two holes found

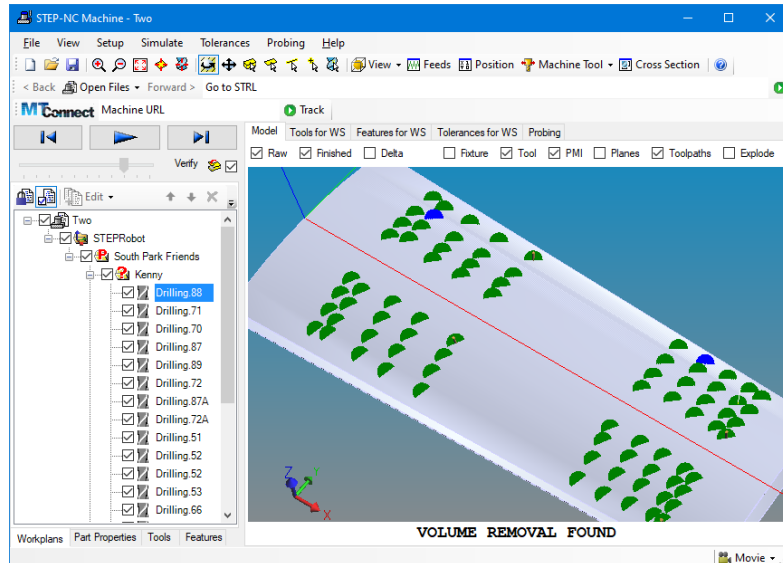

Eight holes found

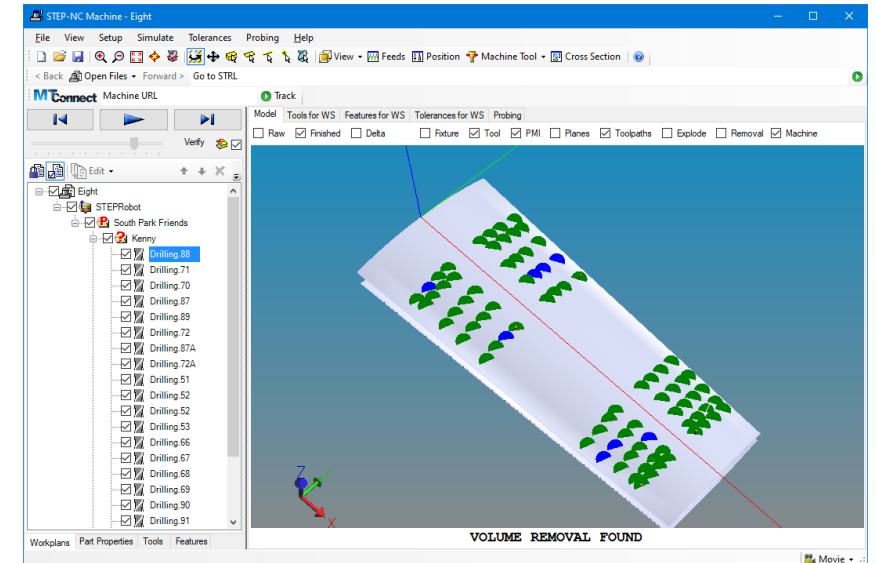

Digital Twin process model

<https://stepmfg.github.io/ap238e2/data/clause5.htm#fig-twinmodel>

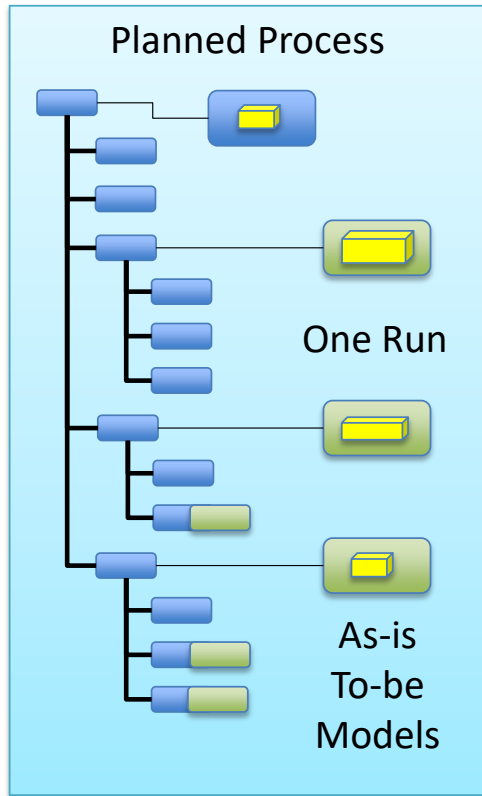

Model process state using new attributes

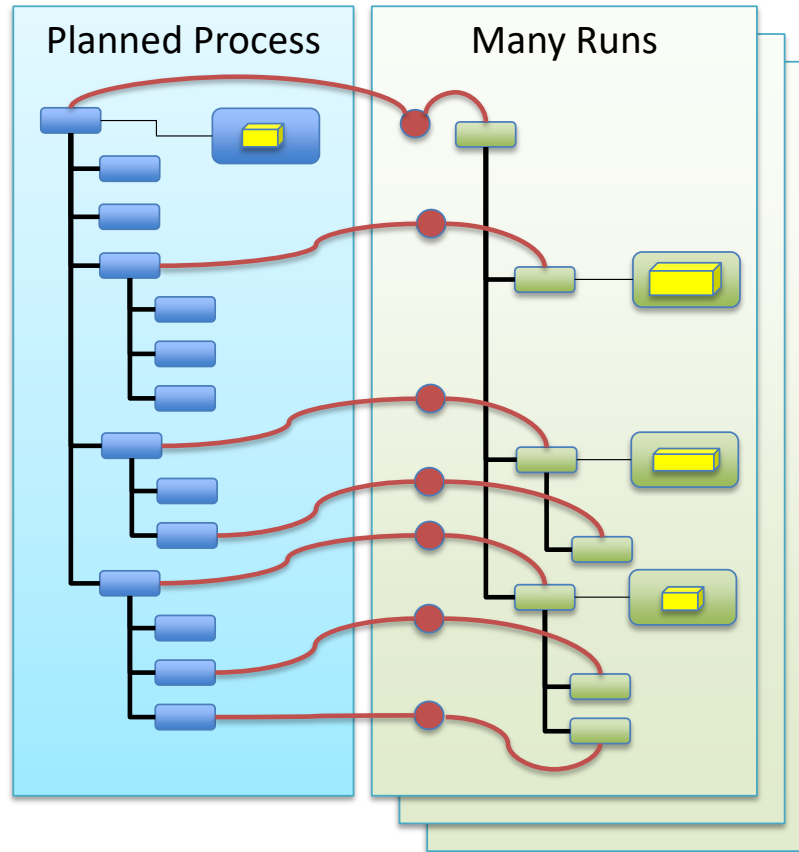

Link runs using Part 21 Edition 3

ENTITY executable

```
[ ... other attributes omitted ... ]  
twin_source: OPTIONAL twin_source_enum;  
twin_plan: OPTIONAL executable;  
twinning_start : OPTIONAL Date_time;  
twinning_end :   OPTIONAL Date_time;  
twinning_exception : LIST [0:?] explanation;  
nominal_in_cut_time: OPTIONAL Time;  
actual_in_cut_time : OPTIONAL Time;  
nominal_ws_time : OPTIONAL Time;  
descriptions : LIST [0:?] line;  
END_ENTITY;
```

```
TYPE twin_state_enum = ENUMERATION OF (simulated, machined); END_TYPE;
```

Executable is supertype of all processes.

Definition above shows new attributes for Edition 2

- Hole.1 (ROUND_HOLE)
- Hole.2 (ROUND_HOLE)
- Hole.3 (ROUND_HOLE)
- Hole.4 (ROUND_HOLE)
- Hole.5 (ROUND_HOLE)
- Hole.6 (ROUND_HOLE)**
 - Depth = 0.39 in
 - Diameter = 0.19 in
 - Position = (11.354, 1.149, 0.34) in
 - Bottom type = CONICAL_HOLE_BOTTOM
 - Tools
 - Tool - T6, D=0.19, L=1.96850393700787
 - Workingsteps
 - Drilling.6
 - Entity = 17463 Started = 2020-07-21T09:16:29.701-04:00
 - Ended =
 - Elapsed time =
- Hole.7 (ROUND_HOLE)
- Hole.8 (ROUND_HOLE)
- Hole.9 (ROUND_HOLE)
- Hole.10 (ROUND_HOLE)
- Hole.11 (ROUND_HOLE)
- Hole.12 (ROUND_HOLE)
- Hole.13 (ROUND_HOLE)
- Hole.14 (ROUND_HOLE)
 - Depth = 0.387 in
 - Diameter = 0.19 in
 - Position = (7.554, 1.139, 0.372) in
 - Bottom type = CONICAL_HOLE_BOTTOM
 - Tools
 - Tool - T6, D=0.19, L=1.96850393700787
 - Workingsteps
 - Drilling.14
 - Entity = 17391 Started = 2020-07-21T09:16:01.341-04:00
 - Ended = 2020-07-21T09:16:25.616-04:00
 - Elapsed = 24 seconds, 275 milliseconds
- Hole.15 (ROUND_HOLE)
- Hole.16 (ROUND_HOLE)
- Hole.17 (ROUND_HOLE)
- Hole.18 (ROUND_HOLE)

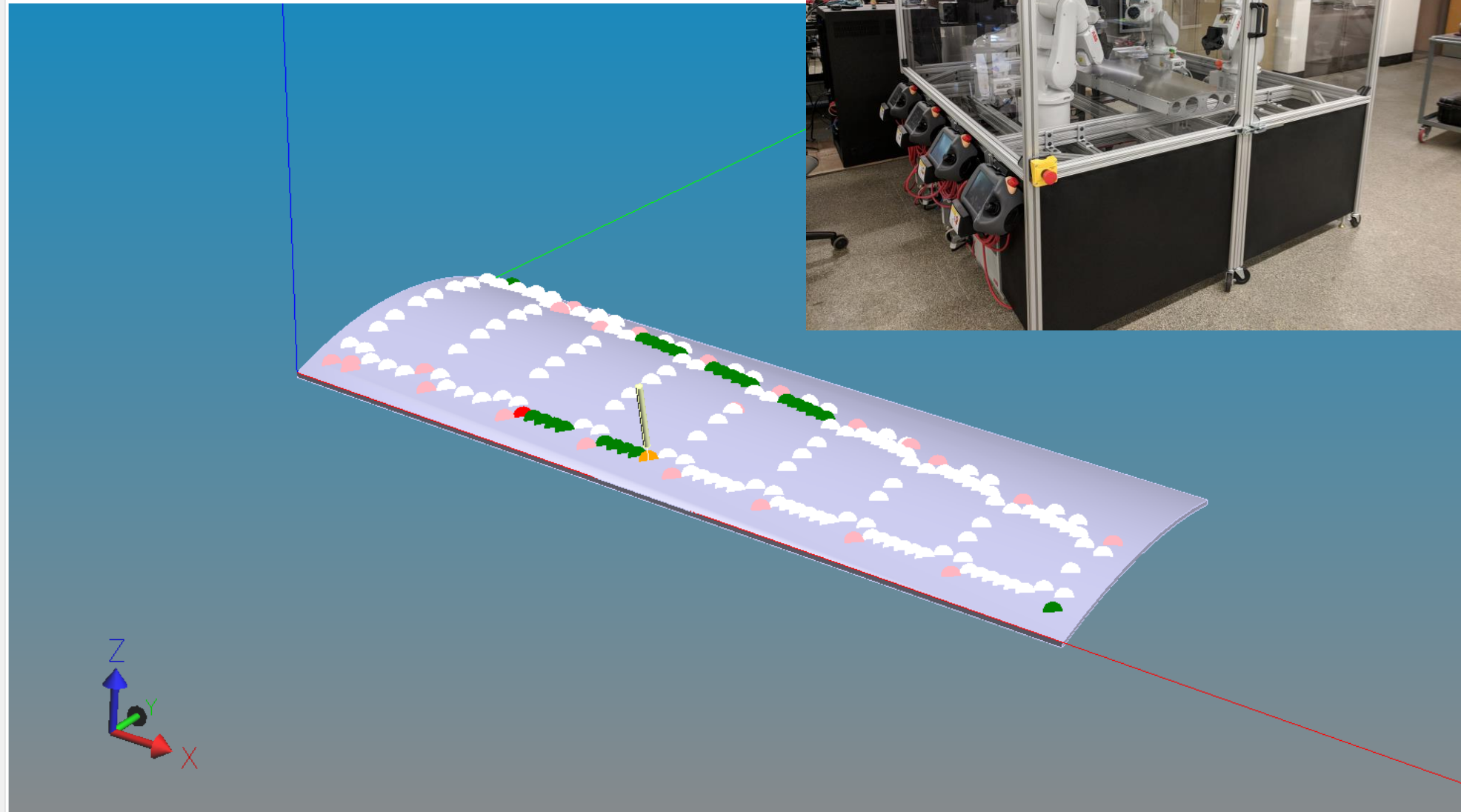

White (ready) Green (complete) Orange (in process) Red (error) Pink (missing data)

Schedule

	☰	▾ CAD /CAM	25 days	Mon 7/6/20	Sat 8/8/20	
/	★	CATIA V5 -> AP238	0 days	Mon 7/20/20	Mon 7/20/20	
	★	Supervisory Control	6 days	Mon 7/20/20	Mon 7/27/20	
/	★	AP238 -> Rapid	6 days	Mon 7/20/20	Mon 7/27/20	
/	★	Setup OPC/UA Server	16 days	Mon 7/6/20	Mon 7/27/20	
/	★	Define OPC/UA Tags	3 days	Mon 7/20/20	Wed 7/22/20	
	★	Define MTConnect Tags	3 days	Thu 7/23/20	Mon 7/27/20	30
	★?	Setup MTConnect Adapter/Agent				
🚒	★	MTConnect -> Digital Twin	7 days	Fri 7/31/20	Sat 8/8/20	31
	☰	▾ State Machine	6 days?	Thu 7/23/20	Thu 7/30/20	
🚒	★	Define OPC/UA Tags	3 days	Thu 7/23/20	Mon 7/27/20	30
	★	Define MTConnect Tags	3 days	Tue 7/28/20	Thu 7/30/20	35
	★?	Map MTConnect to PackML				
	★?	PackML Client				

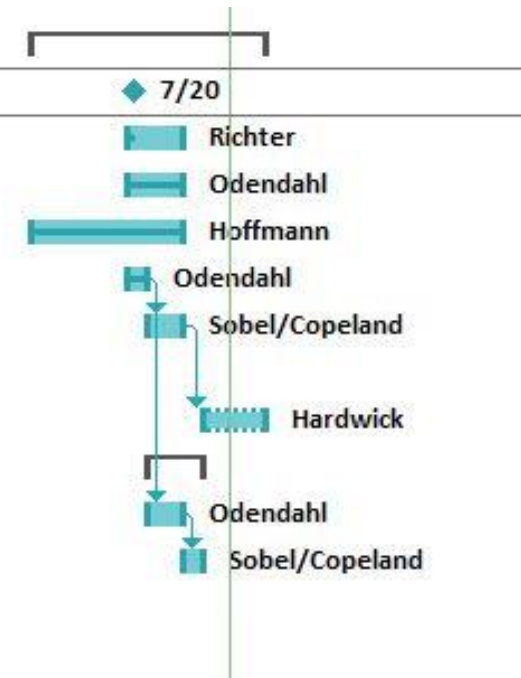

Use Case 2 – weight reduction

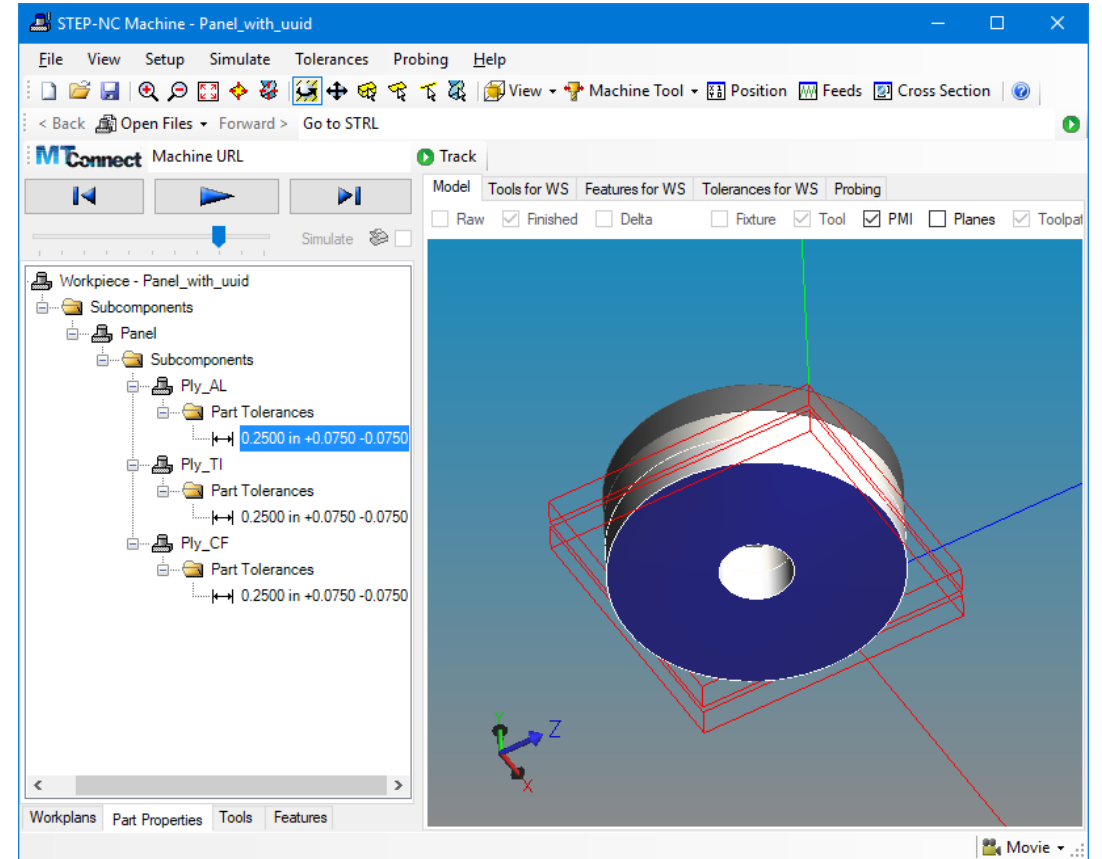
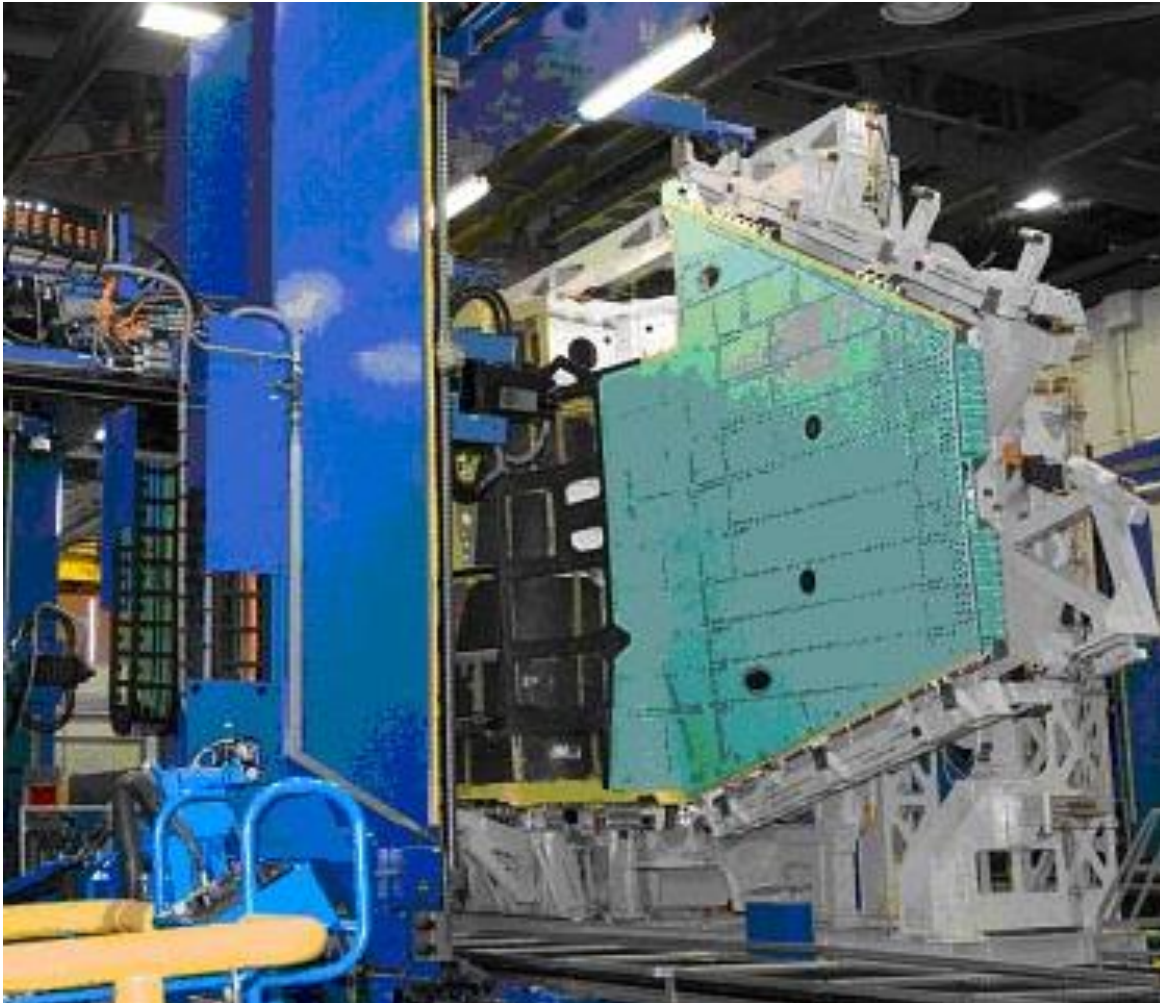

Exact match of fastener to hole depth
can reduce weight by 500lb

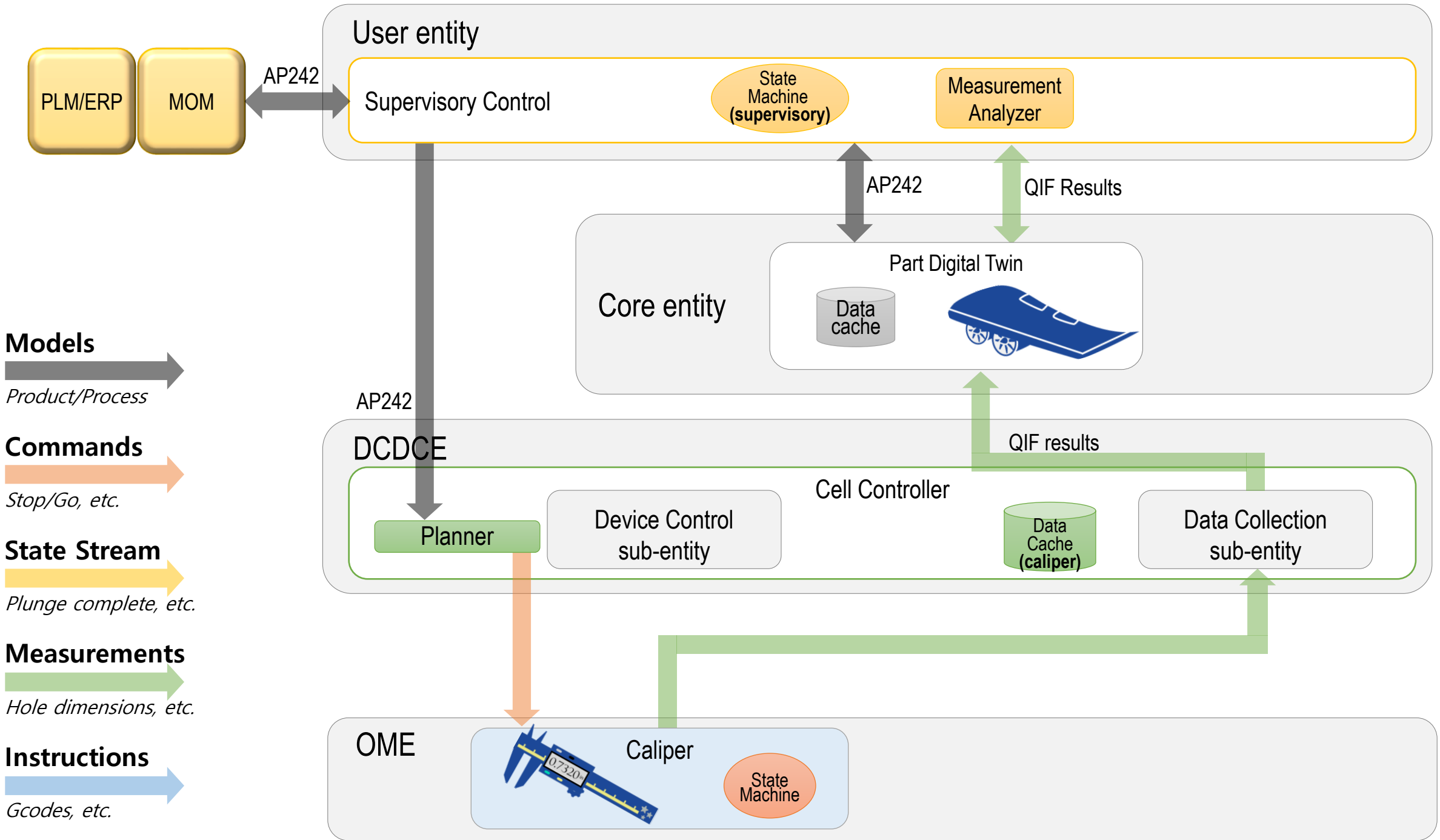

Measurement samples

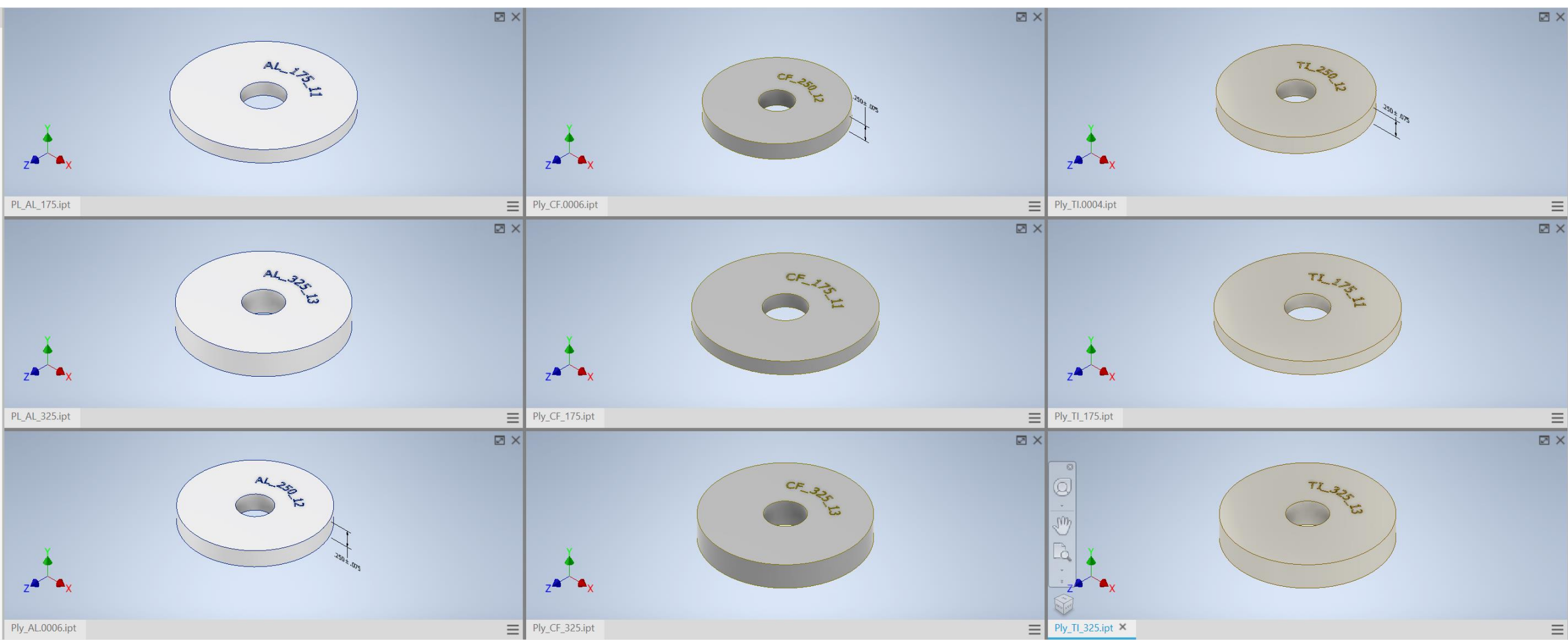

Task	23247 Use Case Reference	Completion Date	Completion %	Status
Define Use Case		16-Mar-20	100%	Complete
Document Use Case		22-Apr-20	100%	Complete
Author MBDs	PLM/ERP	14-May-20	100%	Complete
Export AP242 Nominals	User Entity	14-May-20	100%	Complete
Export QIF Plan	DCDCE	14-May-20	100%	Complete
Measure Parts (key-in)	OME	14-May-20	100%	Complete
Export QIF Measured Results	DCDCE	15-May-20	100%	Complete
Import QIF Measured Results	Core Entity	20-May-20	100%	Complete
Assemble AP242 Digital Twin	User Entity	20-May-20	100%	Complete
Revise Use Case	OME	30-Jun-20	100%	Complete
Receive Fabricated Parts		5-Aug-20		
Measure Parts (as-built)	OME	5-Aug-20		
Internal Rehearsal	OME	7-Aug-20		
Export QIF Measured Results	DCDCE	7-Aug-20		
Import QIF Measured Results	Core Entity	10-Aug-20		
Assemble AP242 Digital Twin	User Entity	14-Aug-20		
Evaluate As-built Digital Twin	PLM/ERP	28-Aug-20		Rehearsal

Use Case 3 – tool life optimization

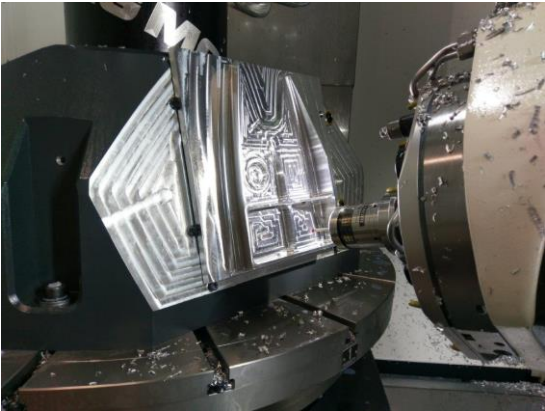

Machine parts

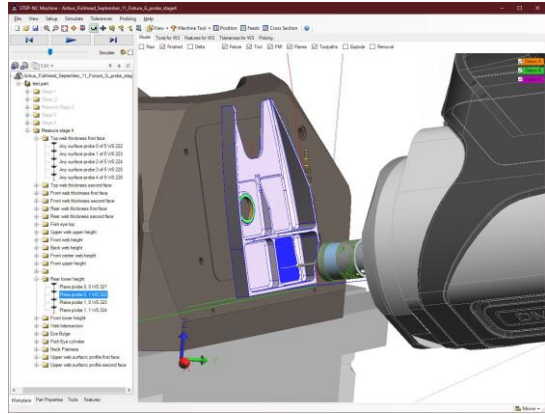

Monitor tool diameter

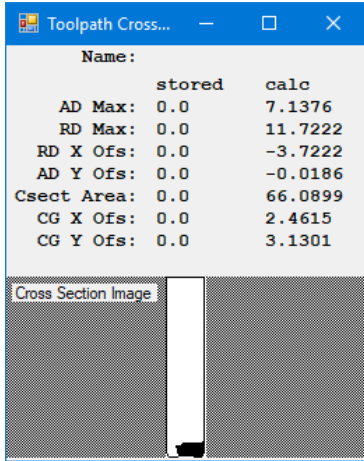

Compute tool engagement

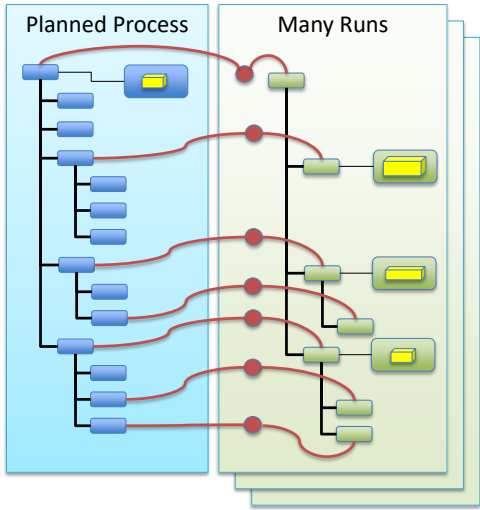
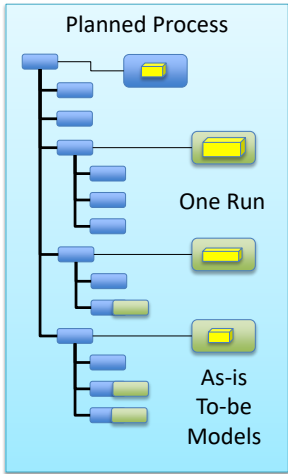

Store linked data

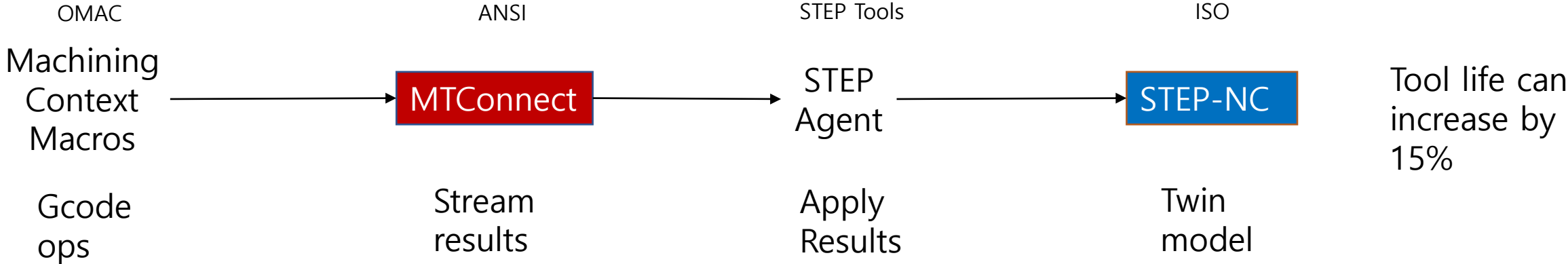

MQTT data

```
test_data = {"projectRelease":"empty","productID": "Boxy_3-Axis",  
,"featureName":"empty","toolClass":"empty", "workingStepName"  
:"OP 3 Fine Milling Datum D, E, F and G", "workingStepDescriptio  
n":"empty", "programVersion":"empty","endofcycle":"empty","pro  
jectStatus":"empty", "workingStepType":"empty", "toolID":"a410a  
ecc-cdd0-4cc4-890e-cdbbca53ee40", "productVersion":"empty","to  
olDescription":"empty","featureType":"empty", "workingStepID": "  
empty","operationID":"empty","operationType":"empty", "startofc  
ycle":"2019-04-04 08:46:02.896","projectID":"empty", "programI  
D":"Boxy_3-Axis_Machining_Setup_1.stpnc", "featureID":"empty","  
toolName":"empty"}
```

ISO 23247-4 Figure A.3

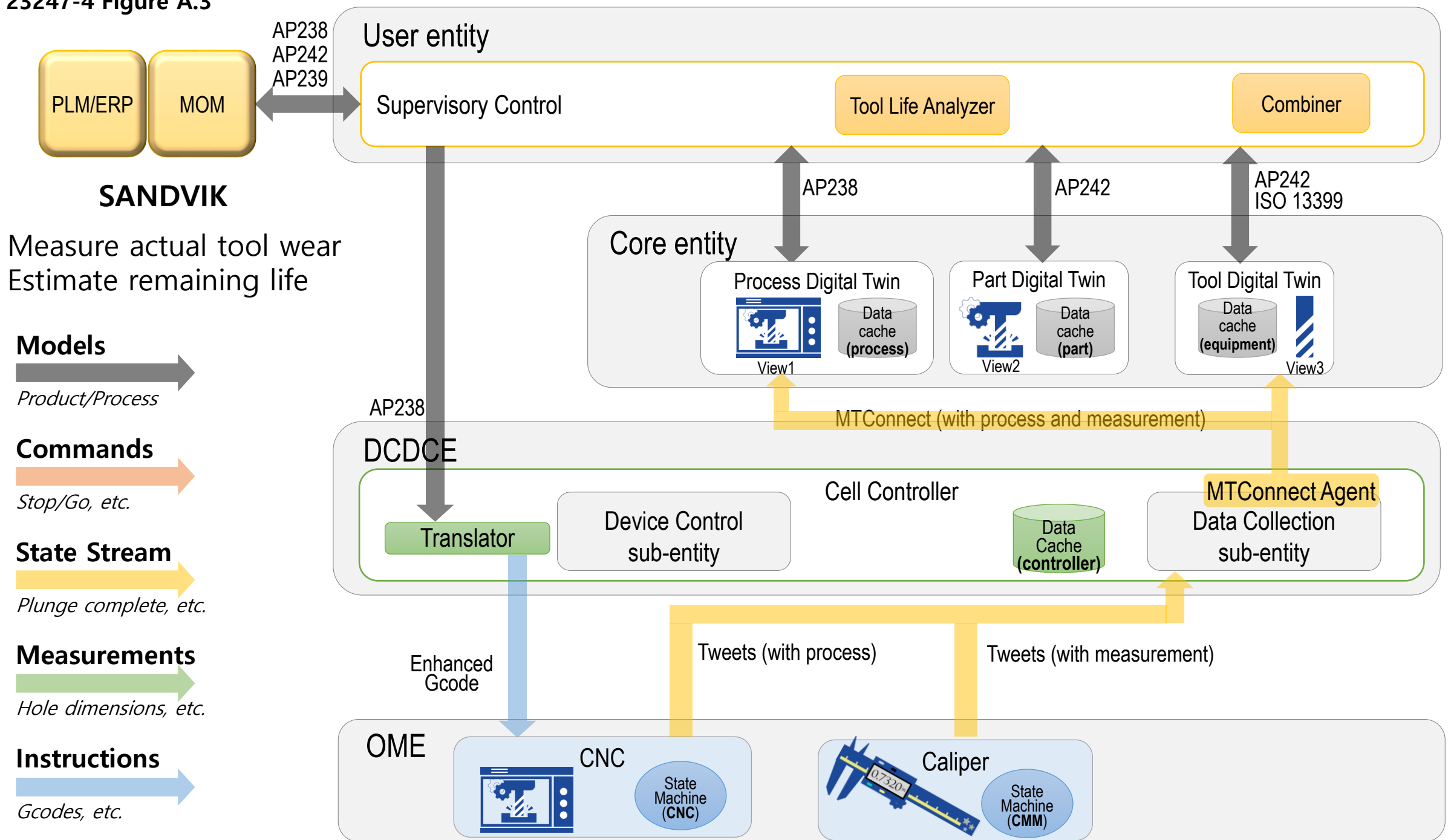

Tool life optimization
-demonstration of feedback
from CNC and Caliper

team and plan set up
(June 30th)

- Bengt Olsson, Sandvik Coromant
 - team leader
 - tooling and process models
- Darya Botkina, KTH
 - enrichment of incoming G-code
 - CNC and Caliper
 - out going tweets
- Will Sobel, Vimana
 - Agent converting tweets to MTConnect stream
- Martin Hardwick, StepTools
 - STEP-NC Machine
 - convert process to G-code
 - read MTConnect stream of process tweets with actual context from CNC
 - read MTConnect stream of measurement tweets with actual context from Caliper
 - combine planned with received
- Jonas Rosén, Eurostep
 - life cycle management
 - actual process
 - actual tools
 - actual parts

selection of process
(July 3rd)

- process
 - Bengt and Darya
- parts
 - Darya
- tools
 - Bengt

process defined
(Aug 4th)

- STEP-NC Machine
- CNC

MTConnect agent
for output of
"tweet streams"
(Aug 11th)

- Create agent for process tweets and measurement tweets
 - Will
- Install agent at KTH
 - Darya

reading of MTConnect
"tweet streams"
(August 11th)

- set up STEP-NC Machine to read tweet streams
- determine real in-cut time (store for "this run")
 - Martin
- set up "life cycle manager" to read tweet streams
 - Jonas

Dry run
(August 18th)

- CNC "process tweets"
 - CNC to STEP-NC Machine to AP238
 - CNC to "life cycle manager" to AP239
- Caliper "part measure tweet"
 - Caliper to STEP-NC Machine to QIF/AP238
 - Caliper to "life cycle manager" to AP239

Demonstration ready
(August 25th)

- Run process
 - CNC at KTH
 - output MTConnect stream
- Measure part
 - Caliper at KTH
 - output MTConnect stream
- Combine information
 - STEP-NC Machine at StepTools
 - read MTConnect streams
 - "real time" viewing
 - output as AP238
 - Manage lifecycle at Eurostep
 - read MTConnect streams
 - output as AP239

August 11 – Action Items

- Use case 1 – MTConnect file for four robots running
- Use case 2 – QIF results file with part measurements
- Use case 3 – MTConnect containing MQTT “tweet” data

Proposed Demonstration Schedule

- September 1 – Dress rehearsal for Use Case 2
- September 8 – Dress rehearsal for Use Case 3
- September 15 – Dress rehearsal for Use Case 1
- September 22 – Final planning for public demonstration
- September 29 – One hour demonstration of the three use cases