

ISO 23247 Digital Twin Use case Testing

May 27 Conference call

ISO 23247-4 Figure A.1

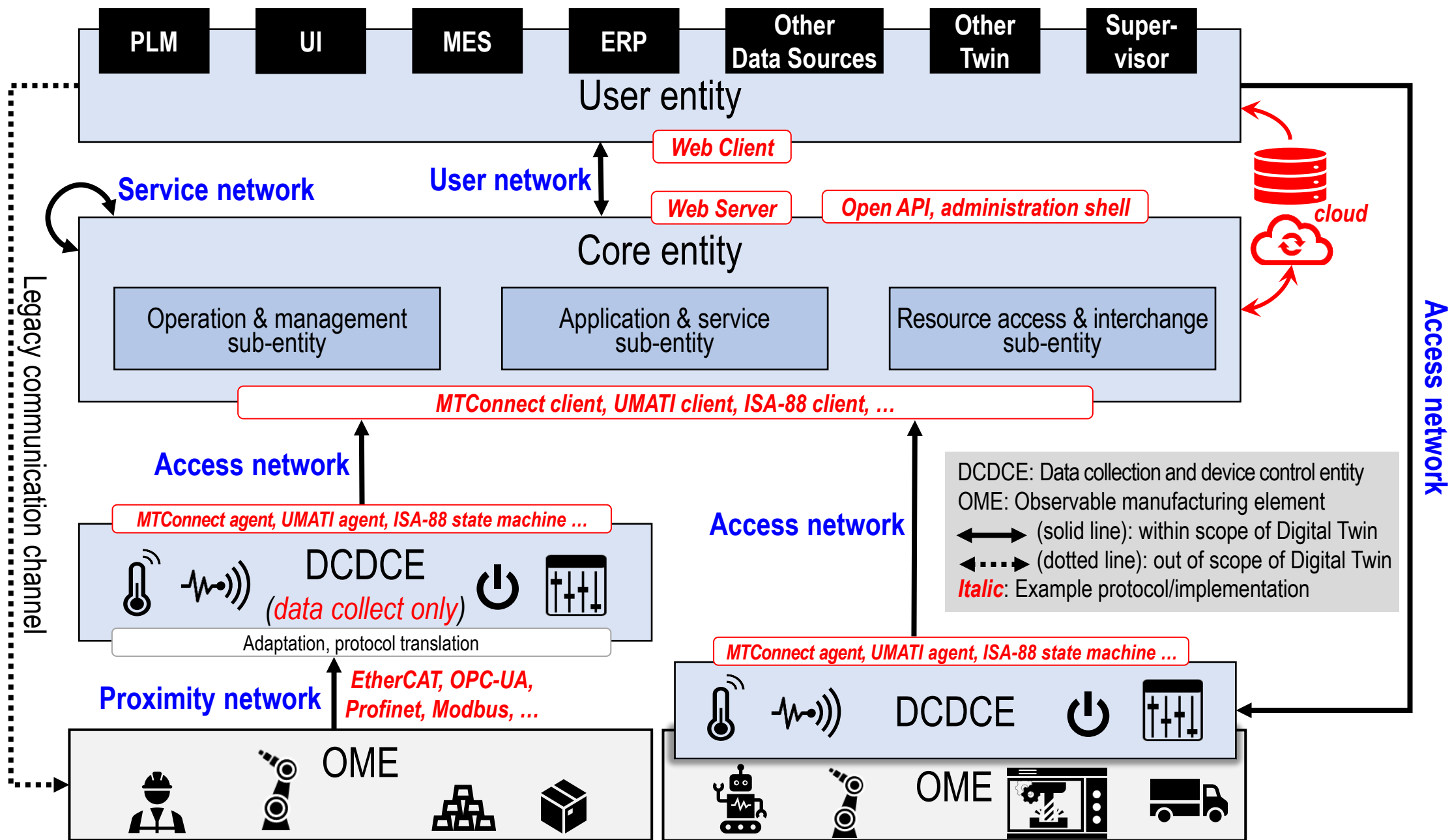

Use Case 1 – robot teaming

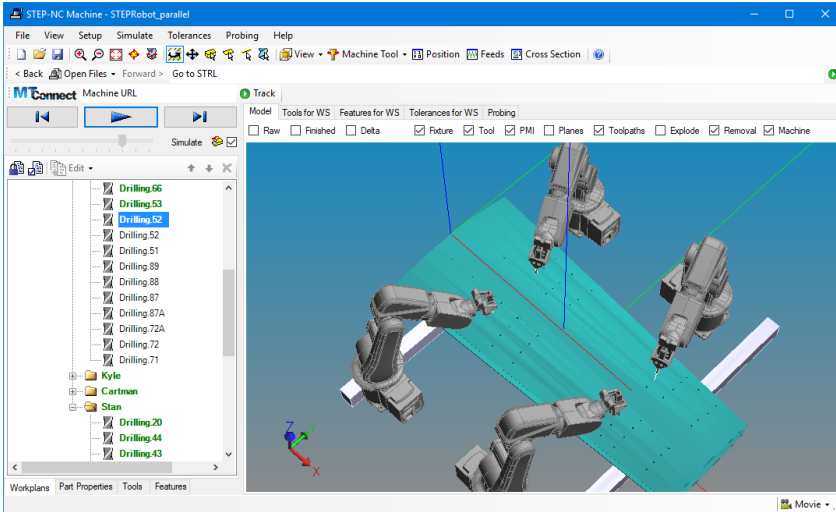
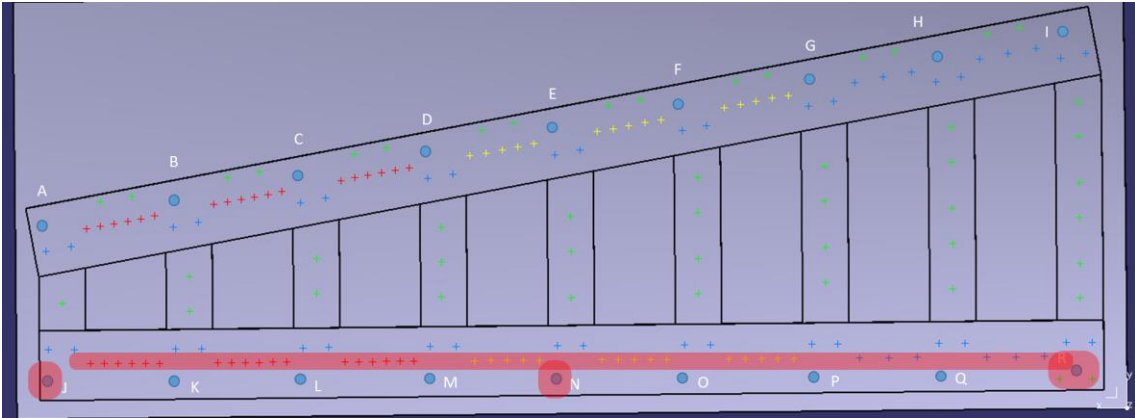
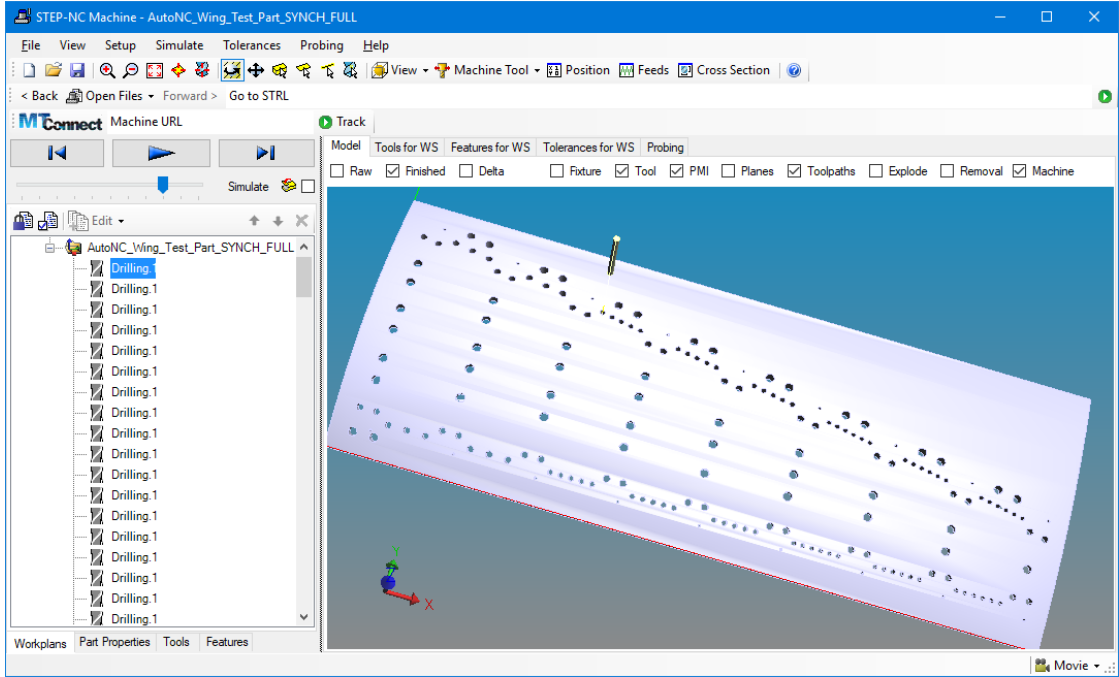

On-shoring can increase by 50%

ISO 23247-4 Figure A.2

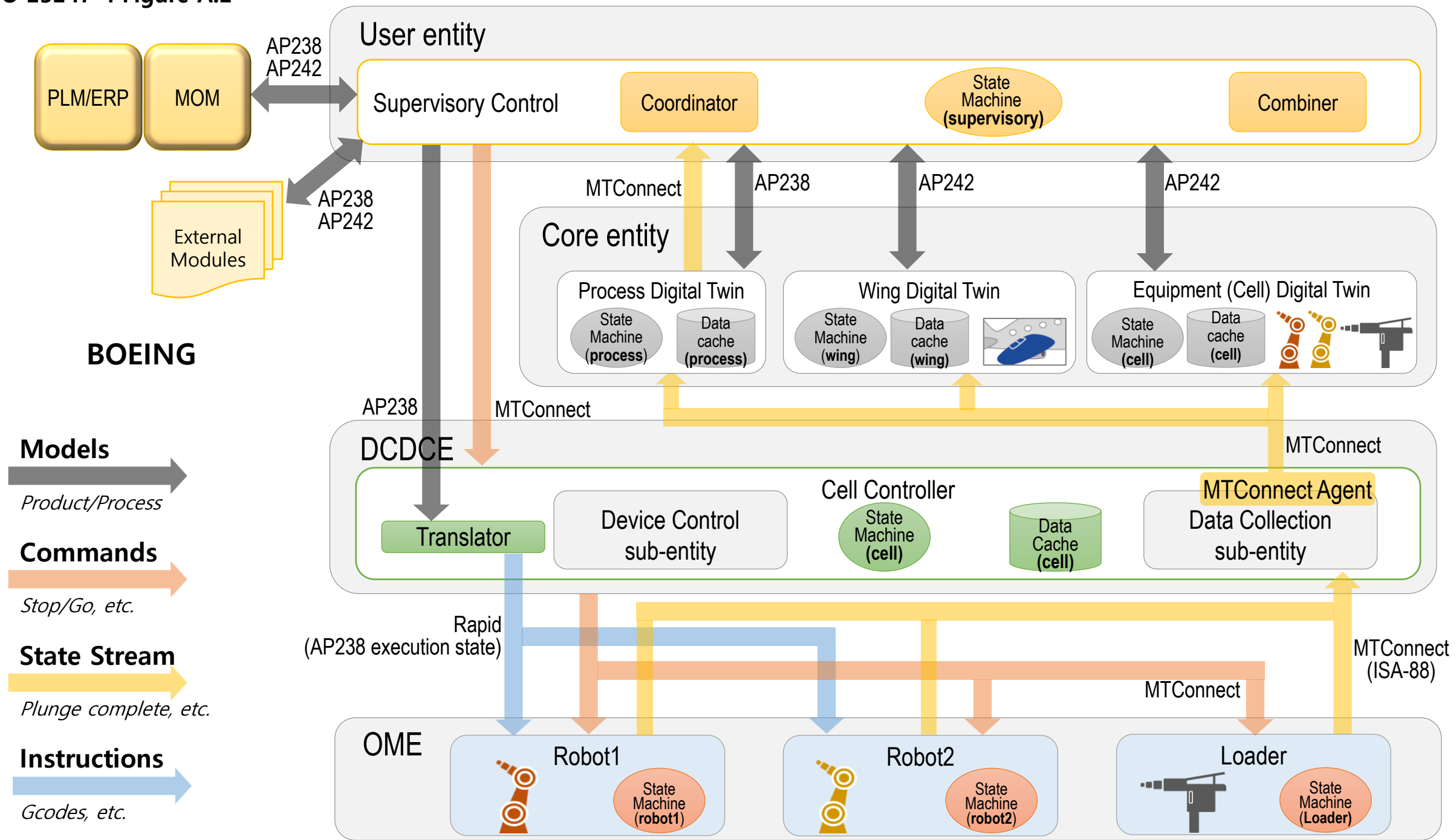

Use Case 2 – weight reduction

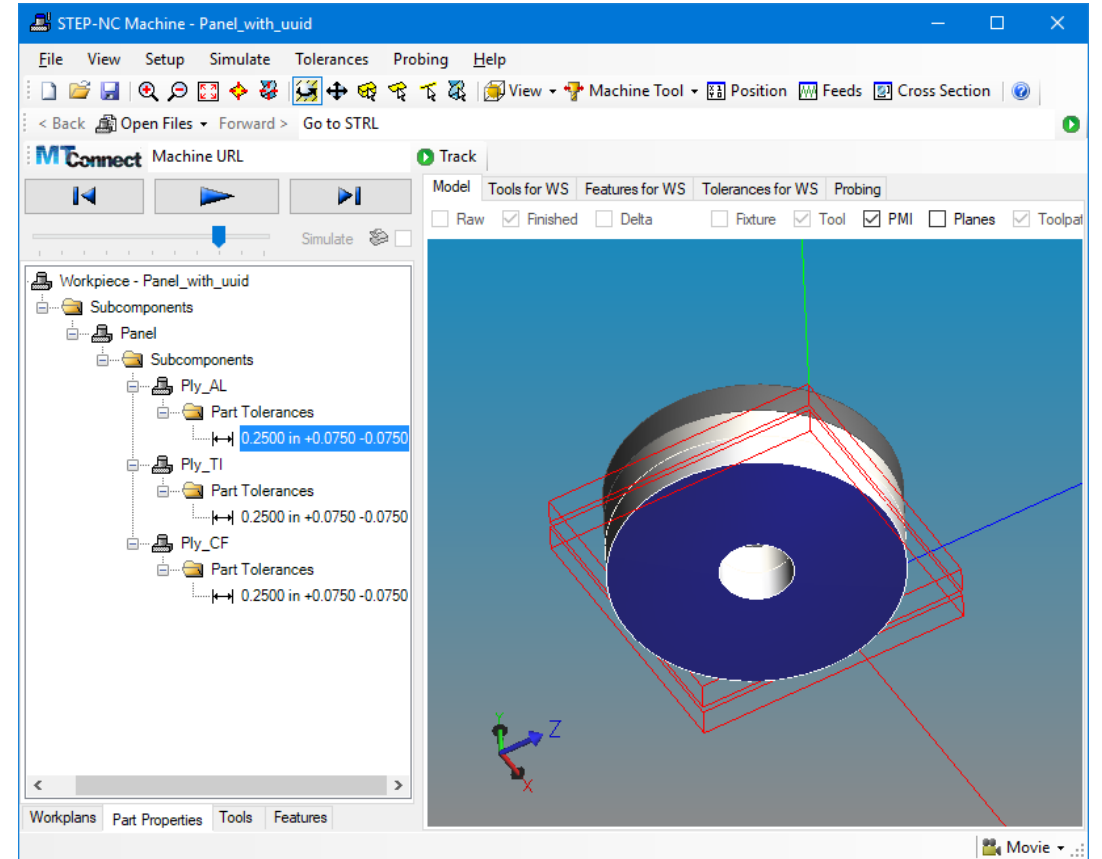
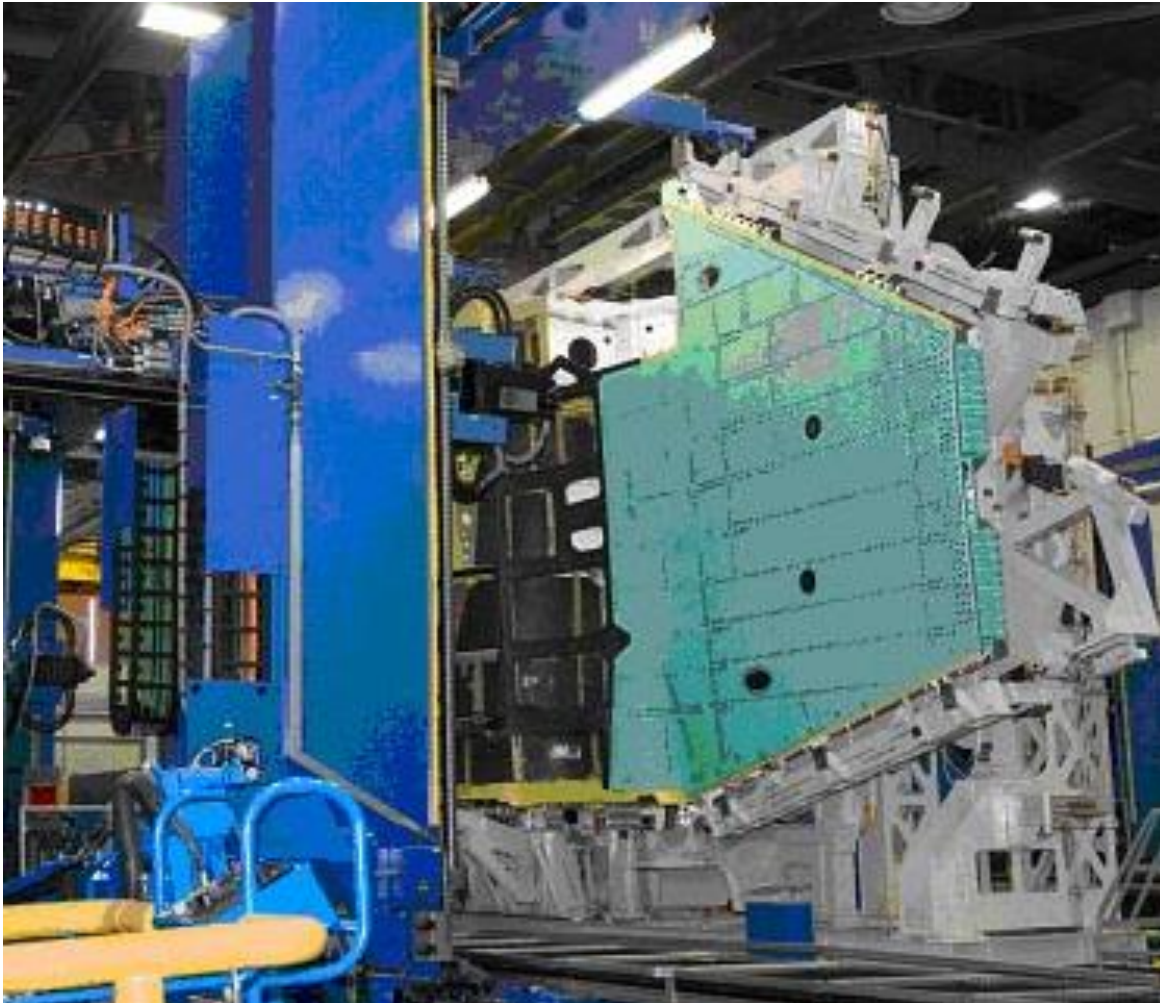

Exact match of fastener to hole depth
can reduce weight by 500lb

ISO 23247-4 Figure A.4

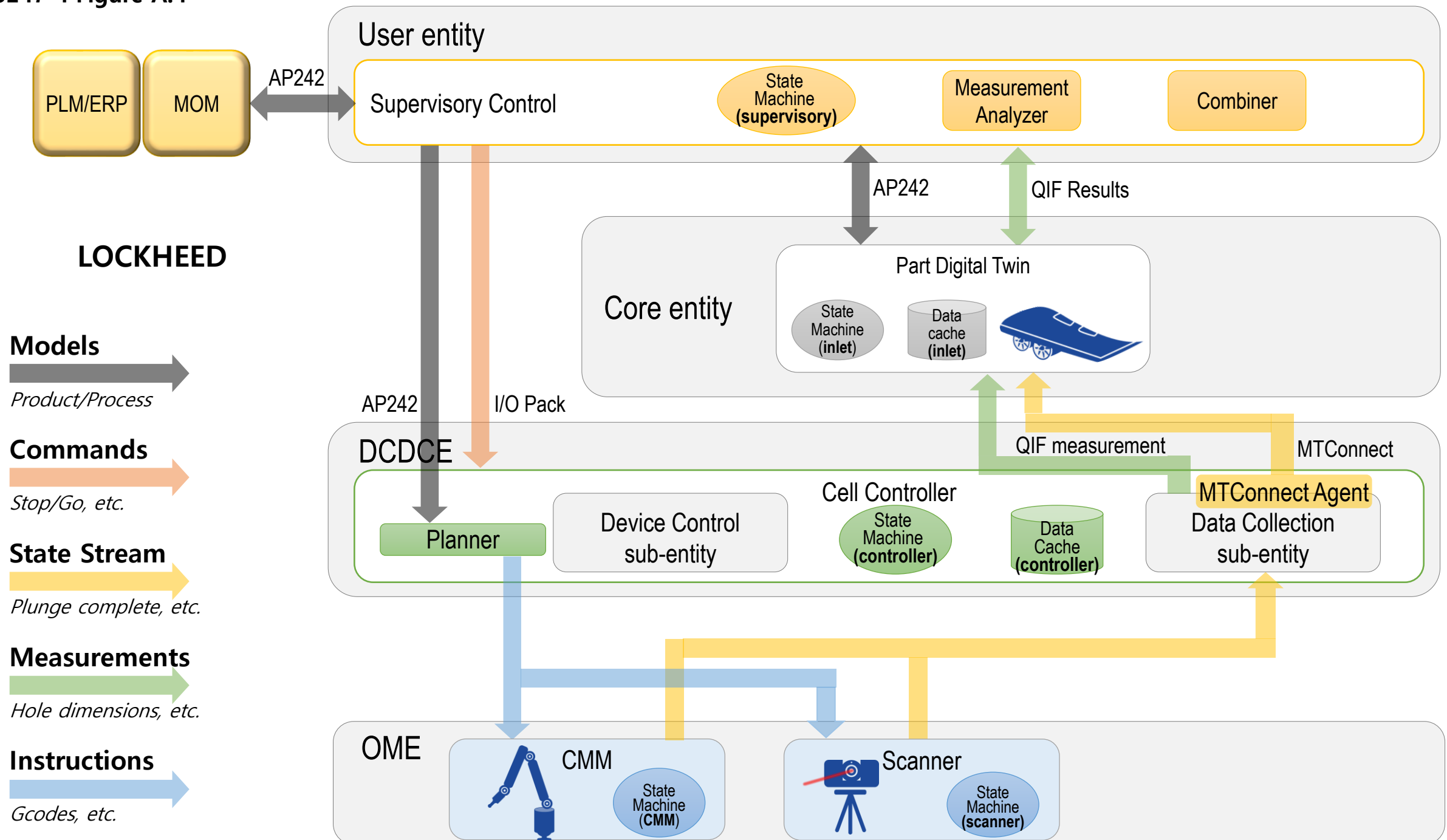

Use Case 3 – tool life optimization

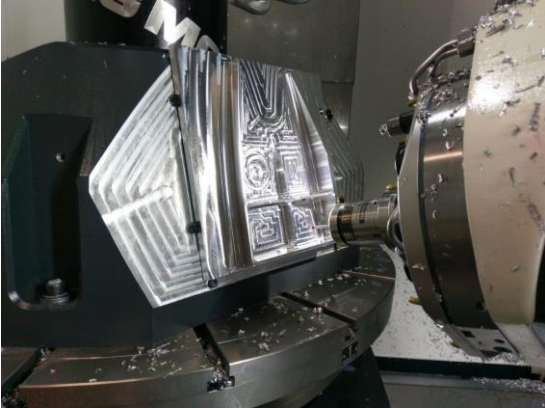

Machine parts

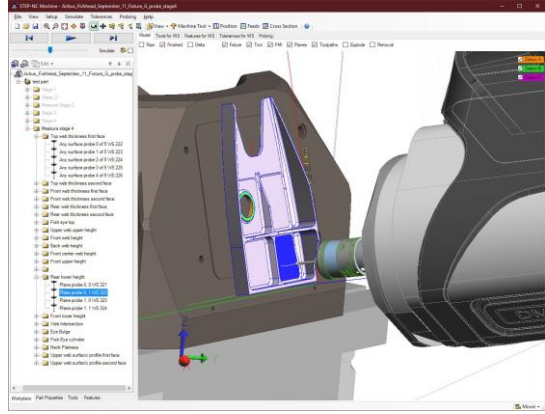

Monitor tool diameter

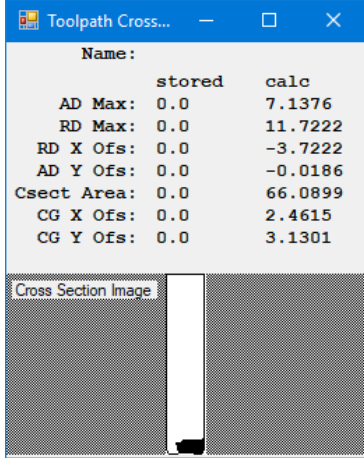

Compute tool engagement

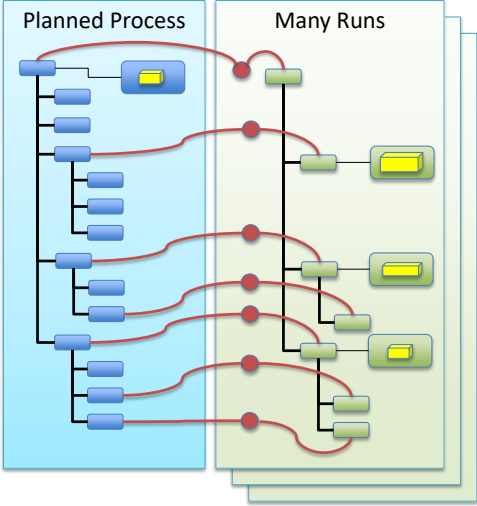
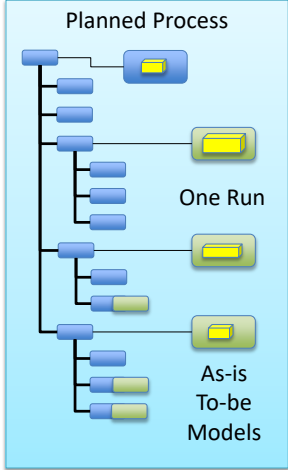

Store linked data

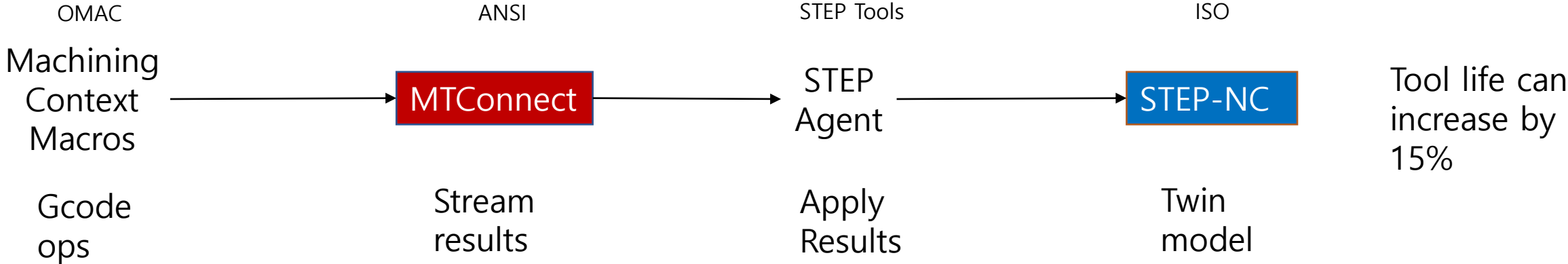

ISO 23247-4 Figure A.3

